

# Determining the Impact of Coefficients of Forced Excitation of Two Different Excitation Control Systems of Large Synchronous Generators on the Transient Stability of Electric Power Systems

**Abstract.** This paper presents a comparative analysis of the impact of the forced excitation coefficients of two different excitation control systems of large synchronous generators on the transient stability of electric power systems. The analysis is based on the mathematical model of the synchronous generator of the seventh order based on Park's transformations and a simplified and sufficiently accurate model of excitation control systems. The model simulates the operation of the generator unit as a one-machine system connected to the infinite bus through a double transmission line during a normal operating regime followed by a short circuit fault disturbance causing challenging the transient stability of the system.

**Streszczenie.** W artykule przedstawiono analizę porównawczą wpływu współczynników wzbudzenia wymuszonego dwóch różnych układów regulacji wzbudzenia dużych generatorów synchronicznych na stabilność przejściową systemów elektroenergetycznych. Do analizy wykorzystano model matematyczny generatora synchronicznego siódmego rzędu oparty na transformacjach Parka oraz uproszczony i wystarczająco dokładny model układów sterowania wzbudzeniem. Model symuluje pracę agregatu prądowórczego jako systemu składającego się z jednej maszyny podłączonej do nieskończonej magistrali za pośrednictwem podwójnej linii przesyłowej podczas normalnego trybu pracy, po którym następuje zakłócenie zwarciowe, powodujące wyzwanie dla przejściowej stabilności systemu. (Wyznaczenie wpływu współczynników wymuszonego wzbudzenia dwóch różnych układów sterowania wzbudzeniem dużych generatorów synchronicznych na stabilność nieustaloną systemów elektroenergetycznych)

**Keywords:** Synchronous generator, excitation systems, transient stability, forced excitation.

**Słowa kluczowe:** Generator synchroniczny, układy wzbudzenia, stabilność przejściowa, wzbudzenie wymuszone.

## Introduction

Excitation control systems of large synchronous generators play a significant role in the stability of electric power systems, especially on their transient or dynamic stability. The importance of excitation control systems in ensuring system stability is enhanced in modern power [1].

This is affected due to several aggravated relevant factors related to stability in such large, interconnected PS such as increased transmission reactance and machine parameters of large new turbogenerator units. More specifically by the prevailing trends in the design and development of new large synchronous generators, which are characterized by further deterioration of electromagnetic or mechanical parameters that results due to the trends and objectives of generator manufacturers of getting the lowest possible cost of generating units, smaller investment volumes per unit of power [2]. The increased generator reactance due to increased magnetic fluxes and their linkages in magnetic circuits is one of the parameters which are decreasing metrics of synchronous generators that is clearly reflected on the system stability [3].

If the negative impacts of the aggravated parameters on the transient and dynamic system stability could not be compensated or if the system's technical criteria in terms of maintaining transient stability of power systems could not be satisfied than manufacture of such large new generator units would not amount to much good [4]. Hence the modern excitation control systems whose impact on the preservation and enhancement of the transient and indeed dynamic power system stability is by far operationally strongest and most efficient has the highest priority in the specter of solutions sought to address and optimize this issue [5]. Furthermore, aiming to additionally enhance and optimize the issue of maintenance of transient stability in large, interconnected power systems.

In view of this excitation control systems of large synchronous machines are the most important for positively

affecting and improving the transient stability of power systems. More specifically, such factors as the excitation voltage ceiling, rate of response of excitation current, average rate of change of excitation current, increase of the excitation voltage towards its ceiling [6]. The magnitude of forced excitation coefficients as well as other parameters such as time constants of excitation control systems, as key factors impacting excitation current improving and enhancing especially the transient power system stability, as well as other system parameters many of which are mutually inter-related [7].

The principal and the final system stability indicator is clearly the load angle representing the angle between the vector of the generated electromotor force (EMF) and the infinite bus voltage vector  $U$  as the reference bus voltage [8]. If the load angle does not exceed the critical load angle value, maximum load angle defining the transient stability limit during the disturbance then the transient stability will be preserved [9]. In view of this the excitation control system must have as fast response as possible, preferably an instantaneous or a nearly step increase of the excitation field voltage with no-delay response practically inertia less in its rise towards the excitation voltage ceiling to argument and preserve transient stability of the system [10]. Such a response is the factor that is related and determines the critical time of the fault clearing time having caused the power system disturbance switch and thus limit and/dampen as much and as fast as possible the disturbance fall out caused by the fault that might have challenged the maintenance of the transient stability of operation of the synchronous generator connected to the infinite bus of the system [11].

The effects of two typical excitation control systems of large synchronous generators in power systems will hence be comparatively analyzed from this perspective in this paper as well as from the aspect of their impact and efficiency of maintaining and enhancing transient stability in

power systems due to serious faults and disturbances. The two such typical excitation systems are:

- Conventional electromechanical DC excitation systems
- Thyristor-rectifier AC excitation systems

The impact of various cases of fault-caused disturbances on the transient stability of the system will be compared based on the related and relevant resulting change of load angle caused by the disturbances affecting and indeed challenging and endangering the maintenance of the transient stability of the power system being analyzed. The three-phase short circuit on large synchronous machine busbars is the gravest of the possible occurring faults that accordingly has the most serious impacts on the generator itself and its transient stability as indeed on the transient stability of the entire power system [12]. However, the three-phase fault short circuit on the generator busbars is extremely/relatively uncommon due to their complete protection and mechanical closure [13]. Hence, for the purpose of this analysis the 3-phase fault will be applied ie simulated relatively and interchangeably close to the beginning of the connecting double transmission line, thus electrically relatively near to the generator busbars.

The two excitation systems analyzed were installed on the generator units of the TPP Kosovo A, the first one initially having been a conventional DC excitation system that was at a later stage reconstructed and replaced with an AC thyristor-controlled excitation system.

### Case study - description of the power system

The case study system is a one-machine system of a synchronous generator connected to the infinite bus of the system through a block-transformer and double transmission lines as shown in Fig. 1.

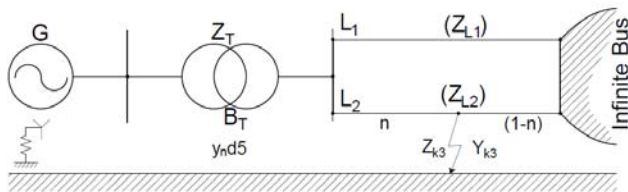

Fig.1. Block-transformer and double transmission lines connected to the infinite bus.

Table 1. TPP KOSOVO A TGV-200 synchronous generator parameters.

Parameter	Unit	Description	Value
$P_n$	MW	Nominal active power	200
$U_n$	kV	Nominal voltage	15.75
$I_n$	kA	Nominal current	8.25
$\cos \varphi_n$		Power factor	0.85
$GD^2$	tm <sup>2</sup>	Generator flywheel moment of inertia	25
$x''_d$		Direct – axis subtransient reactance	0.19
$x'_d$		Direct – axis transient reactance	0.295
$x_d$		Direct – axis reactance	1.84
$x_\gamma$		Leakage reactance	0.145
$T'_d$	s	Subtransient short circuit time constant	0.1375
$T_d$	s	Short circuit time constant	1.1
$T_{d0}$	s	Open circuit time constant	6.4
$T_a$	s	Amplification time constant	0.447
$T_j$	s	Inertia time constant of inertia	6.040

In the case study the large synchronous generator simulated is of the TGV-200 generator type installed in the Thermal Power Plan Kosovo A /TPP KOSOVO–A/ - three identical generator units. The relevant machine parameters

are given in Table 1. The fault is introduced relatively and interchangeably close to the beginning of the connecting double transmission line as shown below in Fig. 1 describing the case study.

Relevant data for its electromechanical excitation system with DC excitation are shown in Table 2.

Table 2. TPP KOSOVO A - Conventional electromechanical DC excitation control system parameters of the case study TGV-200 generator unit.

Parameter	Unit	Description	Value
$U_{fd}$	V	Field voltage	500
$I_{fd}$	A	Field current	1940
$T_{fd}$	s	Field time constant	1
$U_{fd,max}$	V	Maximum field voltage	980
$I_{fd,max}$	A	Maximum filed current	4100
$dU_{fd,max}/dt$	V/s	Maximum field changing	730

This generator excitation systems of the mentioned three identical units of the TPP KOSOVO – A of type TGV-200 were of a conventional electromechanical DC exciter system with an external mechanical drive provided by a three-phase asynchronous motor mechanically driving the main DC exciter. The main exciter mechanical drive was thus provided as supplied directly from the power plant supply system busbars, practically from an independent power supply source being clearly independent of the generator voltage and/or load.

Hence as such, for the purpose of this analysis it can certainly be considered as a direct excitation system with independent mechanical drive practically mechanically coupled to the generator-turbine axis. Namely the busbars of the power plant supply system can be considered connected to the power system infinite busbar with constant system voltage source providing the asynchronous motor drive of the main exciter with constant torque. In Table 3 are given the relevant data for the block transformer and the double transmission lines.

Table 3. TPP KOSOVO A - Synchronous generator block-transformer and double transmission line data.

Parameter	Unit	Description	Value
$S_n$	MVA	Nominal Power	240
$P_{cu}$	kW	Active losses	950
$U_k$	%	Short circuit current voltage	11.3
$m_{12}$		Transformer ratio	15.75/242
$r_u$	$\Omega/km$	Line resistance	0.08
$x_u$	$\Omega/km$	Line reactance	0.4
$L_1$	km	Line 1 - length	40
$L_2$	km	Lin 2 - length	160

The mathematical model of the synchronous machine is simulated as represented in the complete model of the seventh order based on Park's equations with the set of seven differential equations. The double transmission lines and block-transformer are represented with their line equivalent reactance per unit length. The magnetic saturation component, hysteresis and changes in mechanical moment related to rotational speed changes as well as the turbine governor speed control inertia are considered negligible [14].

### Mathematical model of the synchronous generator

Synchronous generator in this case study contains:

- Three stator windings.
- Three rotor windings.

- a. Excitation winding, and
- b. Two damper windings

Since there are permanent flux linkages among the synchronous generator due to the windings that are magnetically interlinked or coupled, their mutual flux linkages, the respectively derived mutual machine inductances are a function of rotor positions [15]. Thus, due to their permanent rotational changes, these reciprocal mutual flux linkages, or mutual inductances are time-and-position dependent and different for each rotor position on a given time [16]. Based on the Park transformation theory, the three stator phase windings are substituted with two equivalent windings on the two rotational axis d and q [17]. The results in these two equivalent stator windings d and q rotating together with the rotor and its windings and thus providing constant values for all the above-mentioned mutual flux interlinkages and thus in constant values of resulting mutual inductances among the six stator and rotor windings of the synchronous machine making them time-invariant [18]. Thus, the two fictitious equivalent stator windings d and q have the respective values such as voltages, currents, fluxes, and parameters as presented in Fig.2 obtained as projections of the actual phase values a, b, c on the d and q axis of these two fictitious equivalent stator windings [19].

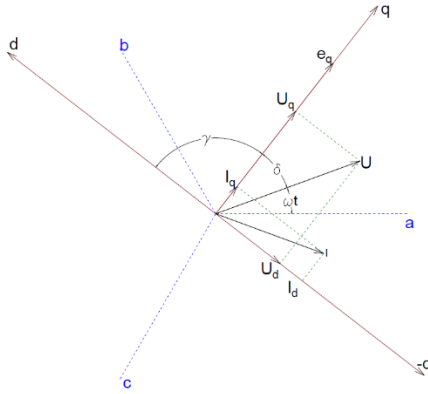

Fig.2. Synchronous generator stator parameters in d-q coordinates

Thus, the mathematical model describing the synchronous generator will be expressed and formulated in the form of the state-space model and respective equation form respectively in the Park's equations summing up the complete set of differential equation the general form of which is [20]:

$$(1) \quad \frac{dx}{dt} = f(X, Y, t)$$

where x represents the state vector respectively the state variables that define the state of the system, y is a driving function.

In this set the linear form of the equation is:

$$(2) \quad G(Y, t) = X$$

According to the general theory of electric machines, Park's equations describe electromagnetic processes in stator windings:

$$(3) \quad u_{fd} = r_{fd} \cdot i_{fd} + \frac{d\Psi_{fd}}{dt}$$

$$(4) \quad 0 = r_{kd} \cdot i_{kd} + \frac{d\Psi_{kd}}{dt}$$

$$(5) \quad 0 = r_{kq} \cdot i_{kq} + \frac{d\Psi_{kq}}{dt}$$

where  $\Psi_{fd}, \Psi_{kd}, \Psi_{kq}$  are rotor windings fluxes,  $u_{fd}, i_{fd}$ , are field voltage and field current,  $i_{kd}, i_{kq}$  are dumping windings

currents in d and q axes,  $r_{fd}$  is field windings resistance,  $r_{kd}, r_{kq}$  are dumping windings resistances in d and q axes.

The differential equation of the second order describing the rotor motion is separated in two differential equations of the first order, which according to Park transformations assume the following form:

$$(6) \quad T_j \frac{d\omega}{dt} = T_t (\Psi_d i_q + \Psi_q i_d)$$

$$(7) \quad \frac{d\gamma}{dt} = \omega$$

where  $T_j$  is rotor mechanical time constant,  $T_t$  is turbine mechanical torque,  $\omega$  – is rotor speed,  $\gamma$  is angle between phase a and d axis,  $\Psi_d, \Psi_q$  are fluxes in d and q axes,  $i_d, i_q$  – d and q component of stator current,  $\gamma$  – angle between phase a and d axis. The synchronous machine fluxes are now defined as follows:

$$(8) \quad \psi_q = x_{kq} i_q + x_{aq} i_{kq}$$

$$(9) \quad \psi_d = x_d i_d + x_{ad} i_{fd} + x_{ad}$$

$$(10) \quad \psi_{kq} = x_{aq} i_q + x_{kq} i_{kq}$$

$$(11) \quad \psi_{fd} = x_{ad} i_d + x_{fd} i_{fd} + x_{ad} i_{kd}$$

$$(12) \quad \psi_{kd} = x_{ad} i_d + x_{ad} i_{fd} + x_{kd} i_{kd}$$

where  $x_{ad}, x_{aq}$  are stator rotor mutual reactance,  $x_{kd}, x_{kq}$  are damper winding reactances in d and q axes,  $x_d, x_q$  – synchronous reactances of synchronous generator in d and q axes.

Because the Park equations must have the general form of equation (1), the currents of each generator winding must be determined from equations (6) and replaced into the set of equations (3-5). Finally, the nonlinear differential equations system assumes the following form [21]:

$$(13) \quad \frac{d\psi_d}{dt} = \psi_q \omega_{ra} \frac{\psi_d (x_{fd} x_{kd} x_{ad}^2) + \psi_{fd} (x_{ad} x_{fd} x_{ad}^2)}{\Delta} + \frac{\psi_{kd} (x_{ad} x_{fd} x_{ad}^2)}{\Delta} - U \cos(\gamma - \omega t)$$

$$(14) \quad \frac{d\psi_q}{dt} = \psi_d \omega_{ra} \frac{\psi_{kq} x_{aq} + \psi_q x_{kq} + \psi_{kd} (x_{ad} x_{fd} x_{ad}^2)}{x_{aq}^2 x_{kq} x_q} - U \cos(\gamma - \omega t)$$

$$(15) \quad \frac{d\psi_{fd}}{dt} = u_{fd} r_{fd} \frac{\psi_d (x_f x_{kd} x_{ad}^2) + \psi_{fd} (x_d x_{kd} x_{ad}^2)}{\Delta} + \frac{\psi_{kd} (x_d x_{ad} x_{ad}^2)}{\Delta}$$

$$(16) \quad \frac{d\psi_{kd}}{dt} = r_{kd} \frac{\psi_{kd} x_{aq} + \psi_{kq} x_q}{\Delta}$$

$$(17) \quad \frac{d\psi_{kq}}{dt} = r_{kq} \frac{\psi_q (x_{fd} x_{ad} x_{ad}^2) + \psi_{fd} (x_d x_{fd} x_{ad}^2)}{x_{aq}^2 x_{kq} x_q}$$

$$(18) \quad \frac{d\omega}{dt} = \frac{1}{T_j} [M_t + \psi_q \frac{\psi_d (x_f x_{kd} x_{ad}^2) + \psi_{fd} (x_{ad} x_d x_{ad}^2)}{\Delta} + \frac{\psi_{kd} (x_{fd} x_{ad} x_{ad}^2)}{\Delta}]$$

$$(19) \quad \psi_d = \frac{\psi_q x_{aq} + \psi_{kq} x_q}{x_{aq}^2 x_{kq} x_q}$$

$$(20) \quad \frac{d\gamma}{dt} = \omega$$

where determinant  $\Delta$  is:

$$(21) \quad \Delta = x_d (x_f x_{kd} - x_{ad}^2) - x_{ad} (x_{ad} x_{kd} - x_{ad}^2) + x_{ad} (x_{ad}^2 - x_f x_{ad})$$

Thus, the entire synchronous machine as a mathematical model is fully described by the set of seven nonlinear differential equations. This represents the mathematical model of the seventh order for the simulated generator that fully and accurately describes the relevant electromagnetic and mechanical processes defined by the state variables of the synchronous machine [22]. It can also be referred to as the full set of seven equations that define the state of a synchronous machine, even though this definition applies to the uncontrolled synchronous generator as it does not include equations excitation control systems or speed governor control [23]. Thus, the generator state variable vector is:

$$(22) \quad [X] = [\psi_d \ \psi_q \ \psi_{fd} \ \psi_{kd} \ \psi_{kq} \ \omega \ \delta]^t$$

where,  $\delta$  represents the generator load angle.

### Mathematical model of excitation control systems

Nowadays, various types of excitation control systems are applied for excitation control of synchronous generators [24]. They can be described analytically using various mathematical models, depending on the type, degree of detail, parameters available or degree of detail required in the analysis [25]. According to the recommendations of the IEEE Excitation Systems Subcommittee Report most synchronous generator excitation control systems may be categorized as Type I of the relevant excitation system division, as illustrated in the schematic block-diagram in Fig.3 [26].

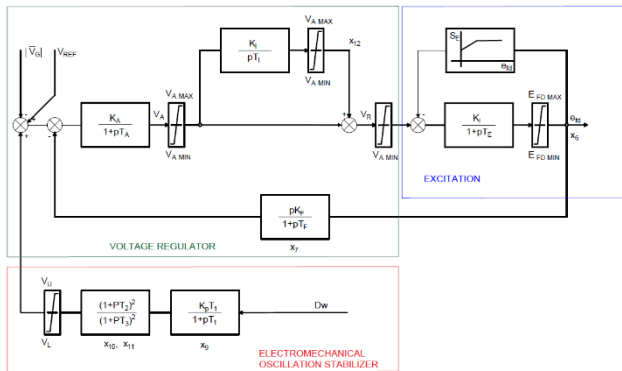

Fig.3. IEEE Excitations System Representation – Type I

The set of three differential equations describing this type of excitation system are given below. They can be obtained from the block diagram of Fig.3 using the inverse Laplace transformations:

$$(23) \quad \frac{du_{fd}}{dt} = \frac{1}{T_{fd}}(K_{fd}u_r - u_{fd})$$

$$(24) \quad \frac{du_r}{dt} = \frac{1}{T_A}[K_A(u_{ref} - u_g - u_{st}) - u_r]$$

$$(25) \quad \frac{du_{st}}{dt} = \frac{1}{T_{st}}(K_{st}K_{fd}u_r - K_{st}u_{fd} - T_{fd}u_{st})$$

where,  $u_r, u_{fd}$  are rotor and exciter voltages,  $u_g$  is bus voltage,  $u_{ref}$  is bus referent voltage,  $K_{fd}$  is excitation forced coefficients,  $K_A$  is amplification coefficient in voltage regulator system,  $T_A$  is amplification time constant,  $T_{fd}$  is excitation time constant,  $T_{st}$  is stabilizer amplification time constant,  $K_{st}$  is stabilizer amplification coefficient.

Thus, the complete full state-space mathematical model synchronous generator with the excitation control system of Type I is described by the set of 10 nonlinear differential equations system providing for a full degree of modelling for

simulation [27]. However, the two excitation systems whose impact on transient stability is being analyzed and studied in this paper can be modelled and mathematically described with sufficient accuracy even without applying the above listed set of differential equations and instead using the simplified model in which the effect of the applied excitation control system can be expressed using purely algebraic expressions in the form of the equation given below (26). This is a solid approximation for proving a sufficiently accurate response of the excitation control system output voltage, while avoiding the additional set of three differential equations. This by implication means avoiding three additional state variables and thus significantly increasing the speed of simulations, decreasing the simulation time and respective requirements on computer resources. The impact of the excitation regulation system on increasing the excitation voltage can be characterized by the following exponential equation given below (26) for the conventional direct electromechanical DC excitation system as schematically shown in Fig.4 [28]. It represents a well approximated functional dependency of the main exciter output voltage and its form and rate of response which is of prime importance for the simulation.

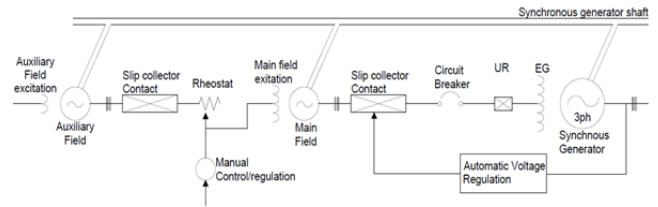

Fig.4. Conventional direct electromechanical DC excitation system.

$$(26) \quad u_{fd} = [u_{fd_n} + (u_{fd_m} - u_{fd_n})(1 - \exp(-t_{over}T_{fd}))]$$

where,  $u_{fd_n}$  is nominal excitation (field) voltage,  $u_{fd_m}$  is maximum excitation (field) voltage,  $t_{over}$  is simulation time.

The additional expressions describing the functional dependency and the relevant constraints of the main exciter output voltage response during operation for this type of excitation control system are given below (27-30) [29]. They represent a credibly approximated simplified analytical set of equations expressed in algebraic form, clearly avoiding unnecessary additional set of three differential equations as given in the following equations [30]:

$$(27) \quad u_{fd} = u_{fd_n} + K_u u_g$$

$$(28) \quad K_{min}u_{fd_n} \leq u_{fd} \leq K_{max}u_{fd_n}$$

$$(29) \quad u_{fd} = K_{max}u_{fd_n} \text{ for } u_{fd} \geq K_{max}u_{fd_n}$$

$$(30) \quad u_{fd} = K_{min}u_{fd_n} \text{ for } u_{fd} \leq K_{min}u_{fd_n}$$

where  $K_{max}$  and  $K_{min}$  are maximal and minimal value of forced excitation coefficients.

Fig.5 shows the schematic diagram of a direct ac thyristor-rectified excitation control system.

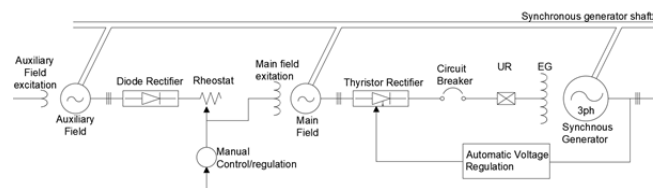

Fig.5. Schematic diagram of the simulated direct ac thyristor-rectified excitation control system.

The above given set of equations in state variable form for the synchronous generator with the fully accurate mathematical model of the seventh order along with its related excitation control system with a simplified mathematical model described with the algebraic equations approximating with sufficient accuracy the entire system. It should be noted that all expressions for the simulation and analysis are given in pu system, including time, which is then easily converted back to the respective original units based on the appropriate proportions of the pu conversions. The reciprocal system of pu system defines 1 pu as the voltage producing the generator nominal voltage in the iron-gap characteristic.

### Results obtained and respective interpretations.

The Numerical methods are used to solve the systems of equations. In this case the Runge-Kutta method of the fourth degree is found to be the most suitable. The solution is preceded by the calculation of all parameters in equations using corresponding expressions obtained from known for the generator and its excitation control system data, as well as for the determination of the fault initial conditions. Determining the initial conditions includes specifying the state vector which contains the synchronous machine's seven state variables [31]. They require determining the generator's stationary operating condition in the system using state variables preceding the fault, which in this case is the nominal operating mode of the generator in the normal operating mode with grid voltage  $U = \text{const}$ .

The fluxes will also be constant in stationary state due to constant inductances; hence their derivatives will be zero. In the nominal operation, the angular velocity is nominal, or 1 pu. The initial values of state variables are calculated for each time increment with the numerical integration of the system of differential equations based on these conditions as applied to the respective set of equations.

A three-phase fault is introduced at the close distance from the beginning of the L2 parallel line as shown in Fig.1, at  $t = 0_+$  for a duration of  $t_{k3} = 0.19$  [sec], after which the protection disconnects the faulted line. Following the simulation, the change in generator load angle is used as a transient stability indication for generators with:

- Direct DC excitation system
- Direct AC thyristor excitation system and simulations are carried out for two different forced excitation coefficients:

$$K_{fs} = 2 \text{ pu}$$

$$K_{fs} = 3 \text{ pu}$$

The transient stability of the system is determined in the first electromechanical oscillation of the power system. For all the four cases simulated and analyzed, the load angle changes are calculated, and respective curves drawn based on the results of the numerical solutions of the differential equations system as graphically displayed in Fig.6. Even with a high forced excitation coefficient of  $K_{fs} = 3 \text{ pu}$  (Figure 6, curve 2), the curves 1 and 2, which describe the change in the generator's load angle of the DC excitation control system reveal that the generator fails to maintain transient stability. This is pronounced even more with a lower forced excitation coefficient of  $K_{fs} = 2 \text{ pu}$  (Fig.6, curve 1).

In the case of the AC thyristor-rectified excitation control system with forced excitation coefficient of 3 pu, as well as for 2 pu, the extremely fast rate of response of the excitation voltage increase allows for maintaining the transient stability (curves 3 and 4) even in the case of short circuits faults close to the generator busbars that are otherwise typically difficult to sustain. This is achieved by

the inertia-less practically zero time constant of the AC thyristor-rectified excitation control systems boosting full excitation practically with no time-delay and almost instantaneous action.

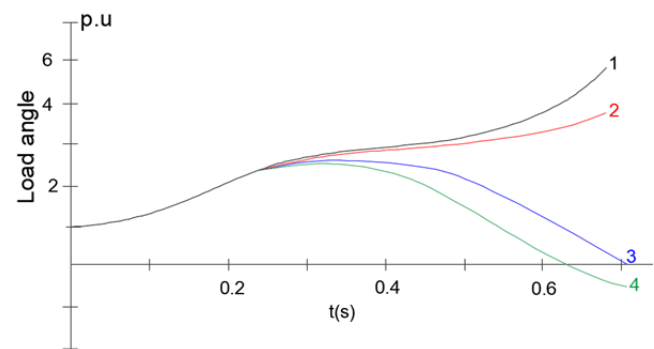

Fig.6. Load angle change of excitation systems.

It can be summarized that the efficiency of thyristor systems in providing efficiently not only maintaining the transient stability, but also for efficiently maintaining of the dynamic, long-term electro-mechanical stability of power systems, as well as providing for other significant advantages over conventional electromechanical systems such as damping electromechanical oscillations in power systems.

The slow rate of response, the increase of the excitation voltage of the DC excitation systems, for both forced excitation coefficients 2 and 3 appear to be linear. Curves 1 and 2 of the excitation voltage change of the conventional DC electromechanical in Fig.7, also due to the scale in the graphic representation, they in fact have exponential forms. However, with a very low gradient, the rate of increase also during forced excitation is insufficient for proving and maintaining transient stability during such fault regimes.

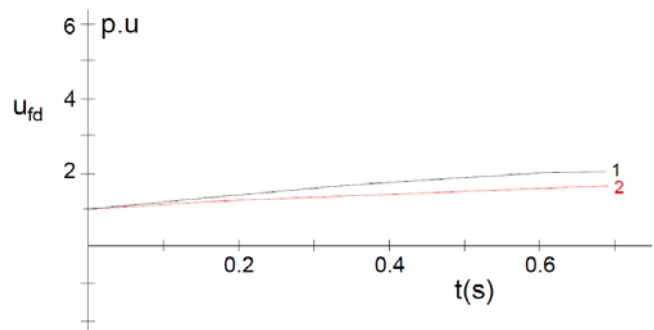

Fig.7. Excitation voltage change of the conventional DC electromechanical excitation system.

Fig.8 shows the AC thyristor excitation control system excitation current changes relating to the aperiodic component of the stator current during the short circuit, which extinguishes with time constant  $T_a$ . The shape of this characteristic curve is fully compatible with what has also been described in the literature [1]. As shown in Fig.8, the change in direct excitation current for the practically inertia-less AC thyristor-control excitation systems, which has the alternative component 50 [Hz] due to the aperiodic component of the stator current during the short circuit being dampened and extinguished with the time constant  $T_a$ .

This characteristic curve's shape is clearly compatible with what is elaborated in the respective literature [2]. Fig. 9 shows the stator current change during fault with the

simultaneous aperiodic component visible due to the asymmetric displacement of the respective oscillogram. Fig.10 shows the curves of the generator electromagnetic torque during faults, respectively, for the conventional DC excitation systems as well as the AC thyristor-rectified excitation control systems. All values are presented in relative or per unit system.

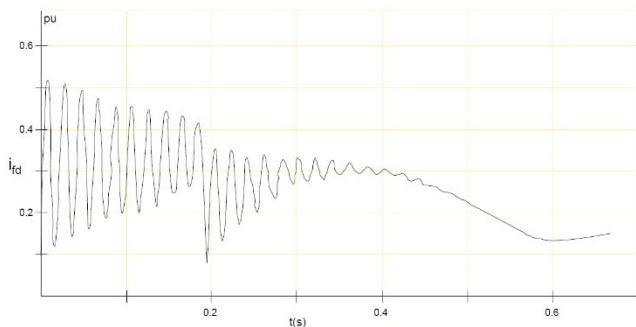

Fig.8. DC field current of thyristor excitation control system related to the aperiodic component of stator current.

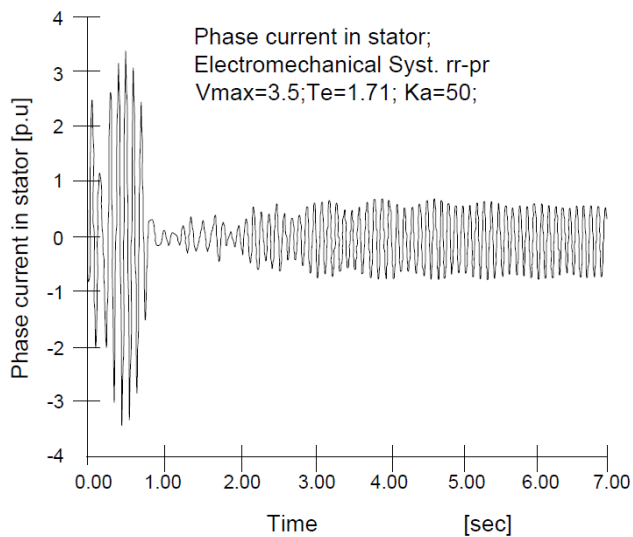

Fig.9. Fault stator current during fault

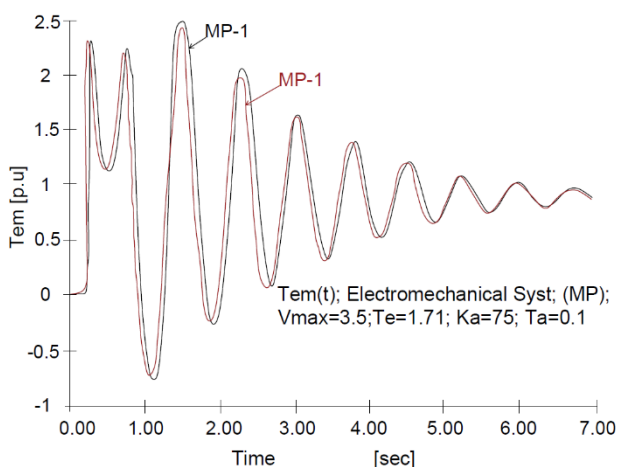

Fig.10. Synchronous generator electromagnetic torques during fault.

## Conclusion

The impact of forced excitation coefficients of two different types of synchronous generator excitation systems

on the transient stability has been analyzed. The two excitation systems analyzed were installed on the generator units of the TPP Kosovo A, the original one being a conventional DC excitation system that was later reconstructed and replaced with an AC thyristor-controlled excitation system. The analysis has yielded the following conclusions.

In terms of synchronous generator transient stability, the thyristor-controlled excitation system is much more efficient in maintaining transient stability than the DC conventional one even for comparatively lower coefficients of forced excitation.

Increasing the forced excitation coefficients of thyristor-controlled excitation systems raises the limit of transient stability and significantly reduces the related electromechanical oscillations.

Increasing the forced excitation coefficient of conventional DC excitation systems has no significant impact on improving or maintaining transient stability.

The excitation control systems of large synchronous generators, especially those operating under challenging transient stability conditions necessarily must be AC thyristor-controlled excitation systems, preferably with higher coefficients of forced excitation.

**Authors:** First author is Prof. Ass. Nuri Berisha, E-mail: nuri.berisha@uni-pr.edu; Second author is Prof. Asoc. Dr. Gazmend Pula\* corresponding author, E-mail: gazmend.pula@uni-pr.edu; Third author is Prof. Acoc. Bahri Prebreza, E-mail: bahri.prebreza@uni-pr.edu; University of Prishtina, Faculty of Electrical and Computer Engineering, Street "Sunny Hill", nn, 10000, Prishtina, fourth author is Ph.Dc. Genc Sejdiu, email: gencsejdiu1@gmail.com, fifth author is Ph.Dc. Petrit Kastrati, email: ppkastrati@gmail.com, sixth author is Asoc. Prof. Dr. Rad Stanev, email: rstanev@tu-sofia.bg.

## REFERENCES

- [1] Kundur P, Paserba J, Vitet S. Overview on definition and classification of power system stability. CIGRE/IEEE PES International Symposium Quality and Security of Electric Power Delivery Systems, 2003 CIGRE/PES 20032003. p. 1-4.
- [2] Kundur PS, Malik OP. Power System Stability and Control. Second edition. ed. New York: McGraw-Hill Education; 2022.
- [3] Machowski J, Lubosny Z, Bialek JW, Bumby JR. Power System Dynamics: Stability and Control: Wiley; 2020.
- [4] Grigsby LL. Power system stability and control: CRC press; 2007.
- [5] Kundur P, Paserba J, Ajarapu V, Andersson G, Bose A, Canizares C, et al. Definition and Classification of Power System Stability IEEE/CIGRE Joint Task Force on Stability Terms and Definitions. IEEE Transactions on Power Systems. 2004; 19:1387-401.
- [6] Savulescu SC. Real-Time Stability Assessment in Modern Power System Control Centers: Wiley; 2009.
- [7] IEEE Recommended Practice for Excitation System Models for Power System Stability Studies. IEEE Std 4215-2016 (Revision of IEEE Std 4215-2005). 2016:1-207.
- [8] Zhongwei Chen, Xudong Zou, Shanxu Duan, Huarong Wei. Research on excitation control system of multi-functional flexible power conditioner. Przegląd Elektrotechniczny, Vol 4/2011, p. 172-175.
- [9] Zhao W, Gao J, Pan Y, Xu P, Li F, Zhang J, et al. Transient Stability Analysis of Virtual Synchronous Generator Integrated Power Systems. 2022 IEEE/IAS Industrial and Commercial Power System Asia (I&CPS Asia)2022. p. 1302-7.
- [10] Hatziaargyriou N, Milanovic J, Rahmann C, Ajarapu V, Canizares C, Erlich I, et al. Definition and Classification of Power System Stability – Revisited & Extended. IEEE Transactions on Power Systems. 2021;36:3271-81.
- [11] Kundur P, Paserba J, Vittal V, Andersson G. Closure of "Definition and Classification of Power System Stability". IEEE Transactions on Power Systems. 2006; 21:446.
- [12] Gui W, Chen X, Zhou H, Yang S, Lu G. Transient running stability assessment of industrial rotating machinery based on

- bag of correlated vibration feature representation. *Measurement Science and Technology*. 2022;34:015110.
- [13] Øyvang T, Heggli GJ, Lie B. Models of synchronous generators with excitation system, for transient power system studies. *IFAC-PapersOnLine*. 2018;51:91-6.
- [14] Redha Djamel Mohammadi, Aissa Souli, Abdelhafid Hellal. Design of a computer code to evaluate the influence of the harmonics in the transient stability studies of electrical networks. *Przeład Elektrotechniczny*, Vol 12/2023, p. 21-25.
- [15] Berisha N, Avdiu N, Stanev R, Stoilov D, Morina S. Dynamic modeling of "KOSOVO A" power station synchronous generator. 2020 21st International Symposium on Electrical Apparatus & Technologies (SIELA)2020. p. 1-5.
- [16] Zhang Q, Gan D, Huang W, Xu H, Wu S, Huang R, et al. Power system small-disturbance stability analysis and control design: A characteristic locus method. *International Journal of Electrical Power & Energy Systems*. 2023;148:108998.
- [17] Moieni A, Kamwa I, Brunelle P, Sybille G. Synchronous Machine Stability Model, an Update to IEEE Std 1110-2002 Data Translation Technique. 2018 IEEE Power & Energy Society General Meeting (PESGM)2018. p. 1-5.
- [18] Shimizu K, Ishigame A. Transient stability assessment application using post-disturbance voltage fluctuations in a multi-machine power system. *International Journal of Electrical Power & Energy Systems*. 2022;139:107987.
- [19] Yadykin I, Iskakov A, Akhmetzyanov A. Stability analysis of large-scale dynamical systems by sub-Gramian approach. *International Journal of Robust and Nonlinear Control*. 2014;24:1361-79.
- [20] Zuhua X, Xiaorong X, Wenjin C, Zhonghong W. Model study of transient stability calculation in power systems. *Proceedings International Conference on Power System Technology2002*. p. 396-400 vol.1.
- [21] Serrano-Jiménez D, Unamuno E, Gil-de-Muro A, Aragon DA, Ceballos S, Barrera JA. Stability tool for electric power systems with a high penetration of electronic power converters. *Electric Power Systems Research*. 2022;210:108115.
- [22] Sedaghati A, Fernández-Ramírez LM. Transient stability study of power systems with high-order models based on hybridizing loop solving and vector computation. *Simulation Modelling Practice and Theory*. 2020;105:102165.
- [23] Mohammadi M, Gharehpetian GB. On-line transient stability assessment of large-scale power systems by using ball vector machines. *Energy Conversion and Management*. 2010;51:640-7.
- [24] Wang L, Klein M, Yirga S, Kundur P. Dynamic reduction of large power systems for stability studies. *IEEE Transactions on Power Systems*. 1997;12:889-95.
- [25] Li X, Li Z, Guan L, Zhu L, Liu F. Review on Transient Voltage Stability of Power System. 2020 IEEE Sustainable Power and Energy Conference (ISPEC)2020. p. 940-7.
- [26] Hajagos L, Basler M. Changes to IEEE 421.5 recommended practice for excitation system models for power system stability studies. *IEEE Power Engineering Society General Meeting*, 2005: IEEE; 2005. p. 334-6.
- [27] Yang H, Niu K, Xu D, Xu S. Analysis of power system transient stability characteristics with the application of massive transient stability simulation data. *Energy Reports*. 2021;7:111-7.
- [28] Anwar N, Hanif A, Khan HF, Ullah MF. Transient stability analysis of the IEEE-9 bus system under multiple contingencies. *Engineering, Technology & Applied Science Research*. 2020;10:5925-32.
- [29] Demetriou P, Asprou M, Quiros-Tortos J, Kyriakides E. Dynamic IEEE Test Systems for Transient Analysis. *IEEE Systems Journal*. 2017;11:2108-17.
- [30] Jia Q, Zhao B, Lin W, Zhong W, Xu S, Xi G, et al. Influence of Synchronous Generator Excitation Parameters on Power System Transient Voltage Stability. 2021 IEEE 4th International Electrical and Energy Conference (CIEEC)2021. p. 1-5.
- [31] Kiryanova N, Kataev D, Yadykin I, Trapeznikov VA. Comparison of two methods of power systems stability degree assessment. 2017 International Conference on Industrial Engineering, Applications and Manufacturing (ICIEAM)2017. p. 1-4.