

# Using nodal specific transportation costs to determine economically beneficial distributed generation source location areas in radial electrical power distribution systems

**Abstract.** It has been suggested using the values of nodal specific transportation cost (STC) in order to determine economically beneficial distributed generation source (DGS) location areas with the focus on radial electrical power distribution systems that are powered by a systemic electrical power supply unit. According to electrical systems, STC is taken to mean active power expenditures for transmitting a unit of active or reactive power to the point of its use.

**Streszczenie.** Zaproponowano wykorzystanie wartości węzłowych kosztów transportu specyficznego do określenia ekonomicznie wykonalnych lokalizacji źródeł generacji rozproszonej, ze szczególnym uwzględnieniem radialnych sieci dystrybucyjnych zasilanych z systemu. Przez określone koszty transportu rozumie się koszty energii czynnej do przesłania jednostki mocy czynnej lub biernej do miejsca jej poboru. (**Wykorzystanie węzłowych kosztów transportu do określenia ekonomicznie wykonalnych lokalizacji źródeł generacji rozproszonej w promieniowych sieciach dystrybucyjnych**)

**Keywords:** radial electrical power distribution system, specific transportation costs, distributed generation sources, gradient method.  
**Słowa kluczowe:** radialna sieć energetyczna, jednostkowe koszty transportu, źródła generacji rozproszonej, metoda gradientowa.

## Introduction

Widespread introduction of DGSs in electrical power systems of various levels of nominal voltage does not only decrease the use of basic fuel and water resources and the expenditures of electrical energy due to bringing them closer to a consumer, but provides the purity of the environment as well. However, when introducing DGSs into electrical power systems, there is a number of problematic issues that require engineering solutions. The most urgent ones include the problem of determining economically beneficial DGS location areas in the correspondent electrical power systems [1–7].

In order to determine economically beneficial DGS location areas, the method of generating the development strategy of electrical systems with phased determination of optimal DGS attachment areas has been applied in the paper [8]. The paper [9] considers optimal DGS location areas aimed at increasing the reliability of energy supply for consumers. When using the suggested approach, which is based on taking into account the integrated influence of DGSs on an electrical system emergency state, a benefit from producing captive electrical power is provided together with the decrease in the number of emergency cut offs for consumers and the downtime of technological equipment. A genetic optimization algorithm has been applied as a means of such optimization. The paper [10] suggests a number of methods to determine DGS location areas in branched radial systems, which are complicated in terms of topology. Their testing for possible use situations has been performed based on probabilistic-statistical modeling procedure (method), taking into account various factors: the volume generated by electrical power sources, the value of consumption in load nodes, load and impedance irregularity in electrical power system elements and others. The analytical approach based on the exact formula of power loss applied for performing optimal locating of one DGS is presented in [11]. The authors of the paper [12] have suggested a new method of power flow calculation as well as an analytical method used for performing optimal locating of several DGSs in a distribution system in order to decrease the costs. The analytical method presented in [13] has been applied to determine the optimal location area of one DGS with a single power factor in both radial and meshed systems in order to minimize losses. However, the optimal value has not been considered in such an approach.

## Methodology

In contrast to the above mentioned approaches used to solve the problem of choosing economically beneficial DGS location areas with the focus on radial distribution systems that are powered by a systemic electrical power supply unit, it was suggested to use nodal STC values, which were determined according to the correspondent mathematical model of the gradient method, which applied the performance characteristics of the results of calculating the maximum or the maximum potential stable load conditions of the electrical power system, where the introduction of DGS was planned, as the basic ones. Here, three types of DGS models were considered:

- 1) DGSs, which simultaneously put out active and reactive power in their location areas in an electrical power system;
- 2) DGSs, which deliver only active power to an electrical power system in the area of their location;
- 3) DGSs, which deliver only reactive power to an electrical power system in the area of their location.

For modeling performance characteristics as the basic ones in terms of developing a mathematical model of the gradient method, which implemented nodal STC, as well as modeling various types of DGSs, the developed mathematical model of a modified Newton method was applied. It is different from the classical one in terms of the possibility to choose the set of known and search nodal characteristics due to the extension of partial derivative matrix by the derivatives from nodal power imbalance (1)

$$(1) \left. \begin{aligned} \varepsilon_i^P &= P_i + U_i^2 G_{ii} - \sum U_i U_j [G_{ij} \cos(\theta_i - \theta_j) + B_{ij} \sin(\theta_i - \theta_j)] \\ \varepsilon_i^Q &= Q_i - U_i^2 B_{ii} - \sum U_i U_j [G_{ij} \sin(\theta_i - \theta_j) - B_{ij} \cos(\theta_i - \theta_j)] \end{aligned} \right\}$$

by search active and reactive power values, and the correction vector is complemented by search active and reactive power corrections. Here, according to the defined DGS types, nodal models are as follows: 1)  $\theta - const, U - const, P - var, Q - var$ ; 2)  $Q - const, \theta - const, P - var, U - var$ ; 3)  $P - const, U - const, Q - var, \theta - var$  the substantiated active and reactive DGS power values in their economically beneficial location areas were determined and the greatest SCT values in the branches of a radial electrical power distribution system were indicated.

According to the modified Newton method [14], the mathematical model of the gradient method that implements nodal STC values, was based on linearized set of equations of the following form:

$$(2) \begin{bmatrix} \frac{\partial \varepsilon_i^P}{\partial P_i} & \frac{\partial \varepsilon_i^P}{\partial Q_i} & \frac{\partial \varepsilon_i^P}{\partial \theta_i} & \frac{\partial \varepsilon_i^P}{\partial U_i} \\ \frac{\partial \varepsilon_i^Q}{\partial P_i} & \frac{\partial \varepsilon_i^Q}{\partial Q_i} & \frac{\partial \varepsilon_i^Q}{\partial \theta_i} & \frac{\partial \varepsilon_i^Q}{\partial U_i} \end{bmatrix}^T \times \begin{bmatrix} \frac{\partial \pi}{\partial P_i} \\ \frac{\partial \pi}{\partial Q_i} \end{bmatrix} = \begin{bmatrix} \frac{\partial \pi}{\partial \theta_i} \\ \frac{\partial \pi}{\partial U_i} \end{bmatrix},$$

where 1)  $[ ]^T$  – a transposed matrix obtained from transposing a partial derivative matrix calculated at the last (finite) iteration when modeling a stable electrical power system mode. The elements of the transposed matrix are partial derivatives of active and reactive power values according to the correspondent search nodal characteristics;

2)  $\pi$  – total active power loss in the elements of an electrical power system diagram, which are determined according to the following formula:

$$(3) \pi = \sum_{k=1}^m [U_i^2 + U_j^2 - 2U_i U_j \cos(\theta_i - \theta_j)] G_{ij}$$

it has been deduced based on the expression of the total power loss in an electrical power system

$$(4) \Delta \dot{S}_\Sigma = \sum_{k=1}^m \Delta \dot{S}_{ij} = \sum_{k=1}^m (\dot{U}_i - \dot{U}_j) \left( \dot{U}_i - \dot{U}_j \right) \dot{Y}_{ij}$$

by conducting a number of transformations and separately providing an active power loss component;

$m$  – the number of electrical power system segments;

3) a vector of search nodal STC values is made up by:

$\partial \pi / \partial P_i$  – the loss of active power for transmitting a unit of active power to the  $i$  – node of the diagram;

$\partial \pi / \partial Q_i$  – the loss of active power for transmitting a unit of reactive power to the  $i$  – node of the diagram;

4) the elements of the vector of absolute terms in the equation system (2) are the following:

$\partial \pi / \partial \theta_i$  – the derivative of the total expenditures of active power in the system elements angularly to the load of the  $i$  – node of the diagram:

$$(5) \frac{\partial \pi}{\partial \theta_i} = \sum_{j=1}^n [2U_i U_j \sin(\theta_i - \theta_j)] G_{ij};$$

$\partial \pi / \partial U_i$  – the derivative of the total expenditures of active power in the system elements by modulus in the load of the  $i$  – node of the diagram:

$$(6) \frac{\partial \pi}{\partial U_i} = \sum_{j=1}^n [2U_i - 2U_j \cos(\theta_i - \theta_j)] G_{ij};$$

$n$  – the number of system segments that are adjacent to the  $i$  – node of the diagram.

Specific transportation costs  $\partial \pi / \partial P_i$  and  $\partial \pi / \partial Q_i$  were determined for all the nodes of the electrical power system and their maximum values indicated the most economically beneficial location areas of active and reactive power, respectively.

In 10 and 35 kV radial electrical power systems with several branches of a systemic electric power supply node, the maximum nodal STC values and, correspondingly, the most economically beneficial location areas of active and reactive power sources were taken into account separately for every branch [15].

Since the derivatives in a partial derivative matrix with respect to search nodal characteristics (2) were not taken from nodal power values  $P_i$  and  $Q_i$ , but from nodal imbalances  $\varepsilon_i^P$  and  $\varepsilon_i^Q$ , the signs of STC element values  $\partial \pi / \partial P_i$  and  $\partial \pi / \partial Q_i$  (before their use) had to be changed into the opposite ones.

The analysis of the function of the total loss of active power in electrical power systems (3) showed that, in case of all the present generation objects (including the source of

a systemic electric power supply unit) dispersed in an electrical power system, the equality of their voltage angles and (or) the equality of voltage moduli resulted in the correspondent change in the angles and (or) the moduli of voltage both in the adjacent nodes and in other consumption nodes between the generation objects. Here, taking into account close relationships between active power and the angles and reactive power and the moduli of nodal voltage, there was power rescheduling between all the generation objects with the loss in the value of the function (3) [16,17].

The indicated functional dependences concerning the equality of angles and (or) moduli of the nodal voltages of generation objects (equality principle) can be considered to be the criterion of active power loss minimization and voltage level stabilization in electrical power systems including radial electrical power distribution ones.

## Results

In order to conduct model experiments to prove the efficiency of using the suggested gradient method for determining economically beneficial DGS location areas in electrical power distribution systems powered by a systemic electrical power supply unit, an algorithm was developed and its software implementation was conducted.

The structure of the developed algorithm is shown in Fig. 1, its software implementation was conducted with the use of Visual Basic 6.0 and C++ algorithmic languages.

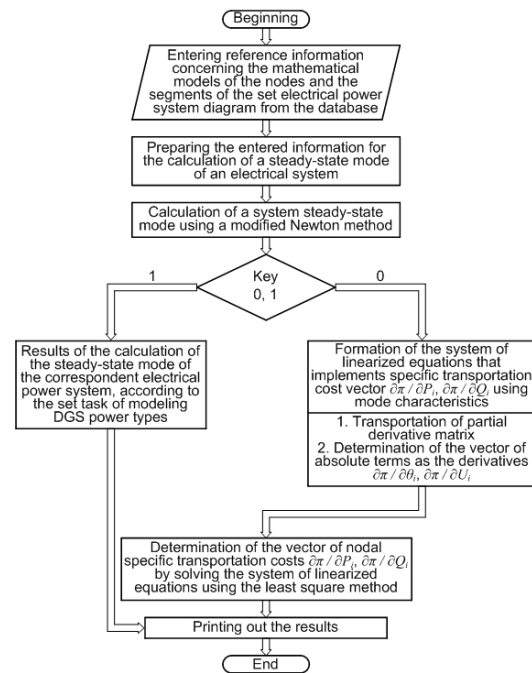

Fig.1. Calculation algorithm of a steady-state mode and the elements of nodal specific transportation cost vector

The developed software with the use of radial electric power distribution systems was applied to determine the voltage values of the generation objects (DGS) and the node of a systemic electrical power supply unit in terms of the principle of their equality according to the criterion of active power loss minimization and voltage level stabilization in electrical power systems.

When modeling radial electrical power distribution system modes, a node of systemic electrical power supply usually acted as a slack one with the preset (known) voltage modulus and the voltage angle which was equal to zero. Thus, voltage angles at the areas of implementing active power sources were equal to the angle of a systemic electrical power supply node.

In order to determine the values of the voltage moduli of a systemic electric power supply node and the implemented sources that generate reactive power, according to the principle of their equality, an analytical and experimental approach with the use of the diagrams of 10 kV electrical power system (Fig. 4) and 35 kV network was applied [17]:

1) a steady-state mode of the correspondent electrical power system was calculated;

2) based on the results of the conducted steady-state mode calculation, the values of nodal STC vector were calculated for all the nodes of the diagram;

3) the node with the greatest values of the vector of nodal STC was chosen according to active and reactive power;

4) the number of electric power system modes was calculated at the constant values of the voltage angles that were equal to zero and the equal voltage moduli of the selected node and the systemic electrical power supply node with their change within the range of 10 kV to 11 kV with the pitch of 0,2 kV in case of 10 kV network and within the range of 35 kV to 38,5 kV with the same pitch in case of 35 kV network; the change in the total power generation of the selected node  $S_g$  and the correspondent change in the loss of active power in the network  $\Delta P$  was graphed;

5) the intercept point of the constructed graphs corresponded to the search voltage modulus – in case of 10 kV networks it was equal to approximately 10,5 kV, Fig. 2 graph (a), and in case of 35 kV – approximately 36,5 kV, Fig. 2 graph (b).

The interception points of the graphs showed both search voltage values and the values of the substantiated total power provided by sources, which was divided into active and reactive power in the calculations.

The fact that the interception points of the dependence graphs in Fig. 2 indicated the substantiated values of the provided active and reactive power by the correspondent sources was proved by the results of the follow-up experimental investigations. In order to prove that the greatest values of nodal STC in a separate branch of an electrical power system indicated the most economically beneficial DGS location areas and their power, which was determined by a modified Newton method, was substantiated, a number of model experiments was

conducted using the diagram of 10 kV radial electrical power distribution system shown in Fig. 4.

1. Model experiments on the implementation of DGS at the coincidence point of the maximum nodal STC in terms of both active and reactive power.

Previously conducted calculations showed that, for example, the greatest nodal STC in terms of active and reactive power coincided in node 448, branch I and were equal to 0,09273 and 0,18715, respectively. Thus, it is recommended to implement DGS, which puts out active and reactive power, in this node. According to the applied modified Newton method and the nodal model, which corresponded to the implementation of DGS, ( $\theta - const, U - const, P - var, Q - var$ ), the calculated values of active and reactive power in this node were equal to:  $P_{g(448)} = 1931,85$  kW,  $Q_{g(448)} = 880$  kVar, Fig. 3 (a and b).

Model experiments on the change in DGS location areas, for example, sequentially in nodes 39, 231, 323 and 230 of this branch, under the condition of preserving the principle of equality of the angles and the voltage moduli in the node of a systemic electrical power supply unit 3333 and the nodes of the change in DGS location areas ( $\theta = 0, U = 10,5$  kV) were conducted. If there was a change in DGS location areas, Fig. 3 (a), the loss of active power in an electrical power system either increased at lower DGS power or decreased, but at higher DGS power relative to the area, which had been determined according to the greatest values of nodal STC (node 448), and the increase or the decrease of the active power generation determined in this node, Fig. 3 (b), resulted in the increase of the loss of active power in the network, which indicated economical practicability according to the determined location area and the sufficiency of the values of active and reactive power of the DGS type, which was recommended for implementation.

2. Model experiments on the implementation of DGS in the location areas, where the maximum values of the nodal STC in terms of active and reactive power relative to different branch segments.

According to previously conducted calculations, the greatest values of nodal STC in terms of active power in branch III related to node 240, and in terms of reactive power they related to node 543 and were equal to 0,01962 and 0,01237, respectively. Thus, it is recommended to implement active power DGS in node 240 and reactive power DGS in node 543. Having applied the modified Newton method and the correspondent DGS nodal models recommended for implementation in node 240 ( $Q - const, \theta - const, P - var, U - var$ ) and node 543 ( $P - const, U - const, Q - var, \theta - var$ ), power in these nodes was calculated to be equal to:  $P_{g(240)} = 1143,07$  kW, Fig. 3 (c and d),  $Q_{g(543)} = 728,2$  kVar, Fig. 3 (e and f).

Separate model experiments were conducted on the change in active power DGS location areas sequentially in nodes 506, 513, 25 and 34 and on the change in reactive power DGS location areas in nodes 72, 239, 513 and 240 of this branch preserving the principle of voltage angle equality in the node of a systemic power supply unit 3333 and the nodes of change in the location areas of active power DGS  $\theta = 0$ , and preserving the principle of voltage modulus equality in the node of a systemic power supply unit and the nodes of change in the location areas of reactive DGS  $U = 10,5$  kV.

If there was a change in the location area of the correspondent DGS, Fig. 3 (c and e), the loss of active power in the electrical power system either increased at lower DGS power, or decreased, but at its higher power relative to the areas, which had been determined according to the greatest values of nodal STC in terms of active power

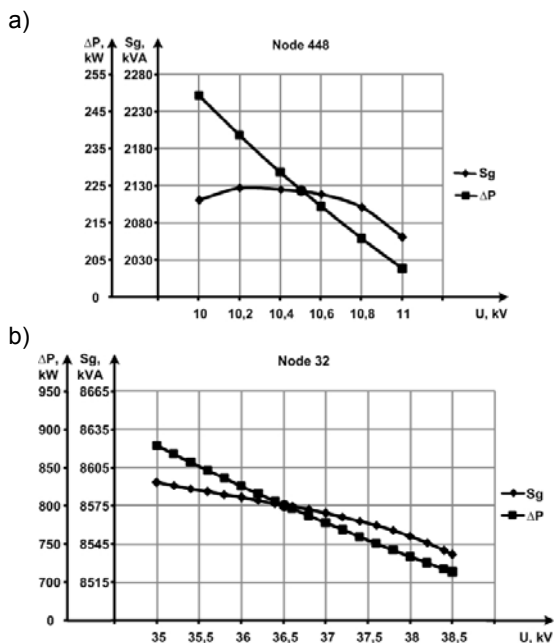

Fig.2. Graphs of determining voltage values in terms of the principle of their equality: (a) according to 10 kV electrical power system, Fig. 4 and (b) according to 35 kV network [17]

(node 240) and reactive power (node 543), which proved economical practicability according to the determined location areas of the recommended DGSs.

In order to prove the sufficiency of active power in node 240 and reactive power in node 543, which were determined according to the applied modified Newton method, separate model experiments were conducted on graphing the dependence of active power loss in the network on the change of active power in node 240, Fig. 3 (d) and the dependence of active power loss in the network on the change of the reactive power in node 543 Fig. 3 (f) at

the preset voltage modulus  $U = 10,5$  kV and voltage angle  $\theta = 0$  in the node of a systemic electrical power supply unit.

The interception point of the constructed graphs, Fig. 3 (d) corresponded to zero voltage angle  $\theta_{240} = 0$  and value of active power being  $P_{g(240)} \approx 1143$  kW, and the interception point of the constructed graphs, Fig. 3 (f) corresponded to the voltage modulus that was equal to the modulus of systemic electric power supply node voltage  $U_{543} = 10,5$  kV and the value of reactive power generation was  $Q_{g(543)} \approx 728$  kVar (proved the principle of equality of nodal voltage angles and moduli).

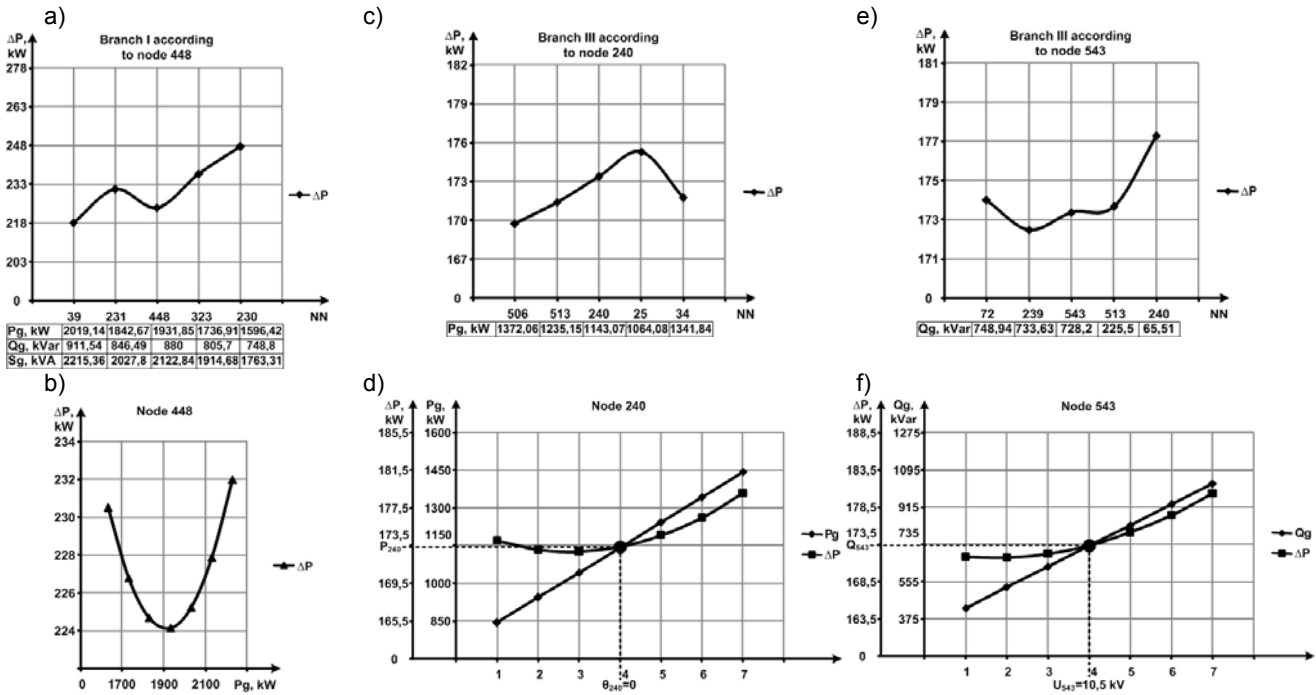

Fig.3. Graphs proving the determination of economically beneficial DGS location areas and the substantiated values of their active and reactive power

According to the graphs in Fig. 3 (d) and Fig. 3 (f), the equality of active power  $P_{g(240)}$  and reactive power  $Q_{g(543)}$  determined by the modified Newton method, proved their practicability.

The results of modeling experiments on the determination of DGS location areas and the values of their power according to branches II, IV and V are shown in the correspondent diagram (Fig. 4).

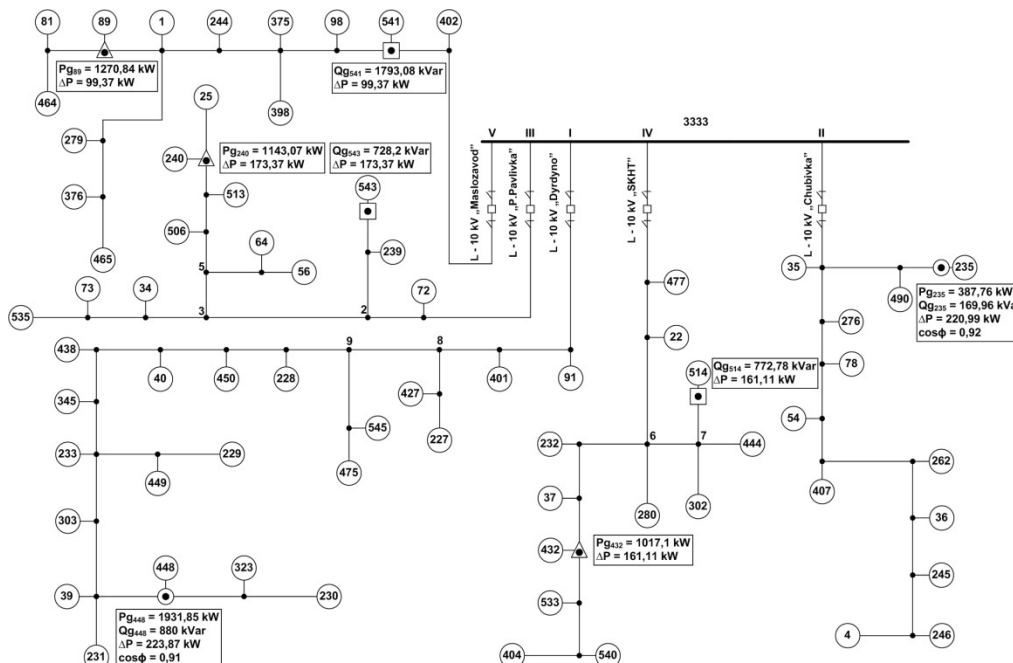

Fig.4. Actual diagram of the calculated radial electrical power distribution system with the plotted investigation results

## Conclusion

1. The use of gradient methods has been first suggested to determine economically beneficial DGS location areas in radial electrical power distribution systems. The most sufficient gradient method has been proved to be the method for determining the loss of active power when transporting a unit of active or reactive power to the place of its consumption, which has implemented nodal STC.

2. The basic matrix for the formation of a transposed matrix in the system of linear equations that implements nodal STC is the matrix of partial derivatives, which is calculated at the last (finite) iteration when modeling a stable electrical power system mode, in this case using a modified Newton method.

3. In case of radial electrical power distribution systems, the greatest nodal STC in every network branch indicates the most economically beneficial location areas of active and reactive power sources, respectively.

4. The analytical analysis of the deduced formula of total active power loss in the elements of electrical power system diagram has made it possible to state that, in case of all the implemented generation objects (including a systemic electrical power supply source) dispersed in an electrical power system, the equality of their voltage angles and (or) the equality of nodal voltage moduli (the principle of equality) can be considered to be the criterion of active power loss minimization and voltage level stabilization in electrical power systems including radial electrical power distribution ones.

5. Calculation algorithms has been developed to calculate a steady-state mode and the elements of nodal STC vector and its software implementation has been performed in order to conduct model experiments aimed at proving the efficiency of using STC in terms of determining the economically beneficial DGS location areas in electrical power systems.

6. The conducted model experiments have proved that functional dependences of the equality of the angles and the moduli of nodal voltages, in case of systemic electrical power supply node and the nodes where active and (or) reactive power is recommended to be implemented, is a criterion of active power loss minimization and voltage level stabilization in radial electrical power distribution systems of various voltage levels. Here, according to Fig. 3, the minimization of the relation between active power loss in the system and the values of active and (or) reactive power generation sources acts as a criterion.

**Authors:** *Anatolii Skrypnyck, candidate of technical sciences, docent of Department of Electricity Supply, Education and Research Institute of Energetics, Automation and Energy Efficiency, National University of Life and Environmental Sciences of Ukraine, Heroiv Oborony str., 15, Kyiv, 03041, Ukraine, E-mail: scripav@ukr.net; Dmytro Kozhan, engineer of Department of Electrical Engineering, Electromechanics and Electrotechnology, Education and Research Institute of Energetics, Automation and Energy Efficiency, National University of Life and Environmental Sciences of Ukraine, Heroiv Oborony str., 15, Kyiv, 03041, Ukraine, E-mail: kozhan14@i.ua.*

## REFERENCES

- [1] Subramanyam T. C., Tulasi Ram S. S., Subrahmanyam J. B. V., Dual stage approach for optimal sizing and siting of fuel cell in distributed generation systems, *Comput. Electr. Eng.*, 69 (2018), 676-689
- [2] Singh N., Ghosh S., Murari K., Optimal Sizing and Placement of DG in a Radial Distribution Network using Sensitivity based Methods, *International Electrical Engineering Journal*, 6 (2015), No. 1, 1727-1734
- [3] Kumar M., Kumar A., Sandhu K. S., Impact of distributed generation on nodal prices in hybrid electricity market, *Materials Today: Proceedings*, 5 (2018), Issue 1, 830-840
- [4] Stanelyte Daiva, Gudzius Saulius, Andriusiene Liudmila, Energy Distribution Planning Models Taxonomy and Methods of Distributed Generation Systems, *Energy Procedia*, 107 (2017), 275-283
- [5] Jegadeesan M., Keerthana V., Optimal Sizing and Placement of Distributed Generation in Radial Distribution Feeder Using Analytical Approach, *International Journal of Innovative Research in Science, Engineering and Technology*, 3 (2014), Issue 3, 358-364
- [6] Priyanka Das, Optimal Sizing And Placement Of Distributed Generation In A Radial Distribution System Using Loss Sensitivity Factor And Firefly Algorithm, *International Journal of scientific research and management (IJSRM)*, 3 (2015), Issue 4, 2611-2618
- [7] Kasaei M. J., Optimal placement of distributed generation and capacitor in distribution networks by ant colony algorithm, *International Journal on Technical and Physical Problems of Engineering (IJTPE)*, 6 (2014), No. 3, Issue 20, 52-56
- [8] Lezhniuk P. D., Rubanenko O. E., Malogulko Yu. V., Optimization of the functioning of the dispersed energy sources in the local electrical systems, *Bulletin NTU KHPI*, (2014), No. 60(1102), 68-77
- [9] Chechushkov D. A., Panikovskaya T. Yu., Bun'kova E. A., A method for optimal deployment of distributed power generation sources to enhance the reliability of power supply, *Industrial Power Engineering*, (2014), No. 9, 17-21
- [10] Popov V. A., Scientific fundamentals for constructing distribution systems with distributed generation sources taking into consideration of information uncertainty: dis. ... doctor of the technical sciences: 05.14.02 / Institute of electrodynamics of the Nation Academy of Sciences of Ukraine, Kiev, (2015), 310 p
- [11] Acharya N., Mahant P., Mitulananthan N., An analytical approach for DG allocation in primary distribution network, *International Journal Electrical Power and Energy Systems*, 28 (2006), Issue 10, 669-678
- [12] Elsaiah S., Benidris M., Mitra J., Analytical approach for placement and sizing of distributed generation on distribution systems, *IET Generation, Transmission & Distribution*, 8 (2014), Issue 6, 1039-1049
- [13] Wang Caisheng, Nehrir M. H., Analytical approaches for optimal placement of distributed generation sources in power systems, *IEEE Transactions on Power Systems*, 19 (2004), Issue 4, 2068-2076
- [14] Skripnik A., Kozhan D., Kovaleva V., Modification of the method of Newton and its use in modes calculation electricity distribution networks with voltage up to 110 kV, *Innovations in agriculture*, (2015), No. 4(14), 14-20
- [15] Skrypnyck A., Kozhan D., Determination of economically perfect places of location and based values of power of sources of distributed generation in distribution electric networks which feed from system electrical supply, *Bulletin of the Kharkiv National Technical University of Agriculture named after Peter Vasylenko*, (2017), Issue 186, 114-118
- [16] Skrypnyck A., Golub B., Kozhan D., Simulation of the established and operating modes of distribution electric networks with voltage 10 – 110 kV, *Mechanization and electrification of agriculture*, (2018), No. 7, 134-145
- [17] Kozhan D., Suggestions for determining of location the sources of distributed generation and the magnitudes of their power in radial electric networks with voltage of 35 kV, *Journal of Rural Production Research, Machinery & Energetics*, 10 (2019), No. 2, 127-133