

# Multi-Sensor System for Monitoring of River Water Pollution

**Abstract.** Rivers play significant roles in communities, including as source of drinking water and for transportation and other daily activities. However, water pollution is a major problem in several communities, with significant negative consequences to health and well-being and socio-economic development. This research, therefore, aimed to design and develop a system with multiple sensors to monitor river water pollution because most communities use river water in their daily activities. In the design and development of the system, multiple sensor nodes were installed for the detection of water pollution parameters such as temperature, Electrical Conductivity (EC), water pH, and Dissolved Oxygen (DO). The system was designed to monitor river water pollution parameters and send the information to the data centre (backend system). Arduino microcontroller was used to process and filter the data before sending to the backend system. Only valuable information was collected and kept in the database. Results show that the system was able to detect polluted water by showing the parameters of interest in a graph. The polluted water indicators were mostly contributed from residential waste and industries. This work has furnished progress in the development and validation of appropriate technologies for tackling river water pollution. In the future, WSNs sensors will be deployed in some areas and the results across the different areas will be compared. Furthermore, the Internet of Things (IoT) Technology will be used for data sharing and communication.

**Streszczenie.** Rzeki odgrywają znaczącą rolę w społecznościach, w tym jako źródło wody pitnej oraz transportu i innych codziennych czynności. Zanieczyszczenie wody stanowi jednak poważny problem w wielu społecznościach, co ma znaczące negatywne konsekwencje dla zdrowia i dobrostanu oraz rozwoju społeczno-gospodarczego. Dlatego te badania miały na celu zaprojektowanie i opracowanie systemu z wieloma czujnikami do monitorowania zanieczyszczenia wód rzecznych, ponieważ większość społeczności wykorzystuje wodę rzeczną w codziennych czynnościach. Podczas projektowania i rozwoju systemu zainstalowano wiele węzłów czujnikowych do wykrywania parametrów zanieczyszczenia wody, takich jak temperatura, przewodność elektryczna (EC), pH wody i rozpuszczony tlen (DO). System został zaprojektowany do monitorowania parametrów zanieczyszczenia wód rzecznych i wysyłania informacji do centrum danych (system zaplecza). Mikrokontroler Arduino został użyty do przetwarzania i filtrowania danych przed wysłaniem do systemu zaplecza. Tylko cenne informacje zostały zebrane i przechowywane w bazie danych. Wyniki pokazują, że system był w stanie wykryć zanieczyszczoną wodę, pokazując interesujące parametry na wykresie. Wskaźniki zanieczyszczonej wody pochodziły głównie z odpadów mieszkaniowych i przemysłu. Prace te zapewniły postęp w opracowywaniu i zatwierdzaniu odpowiednich technologii przeciwdziałania zanieczyszczeniu wód rzecznych. W przyszłości czujniki WSN zostaną wdrożone w niektórych obszarach, a wyniki w różnych obszarach zostaną porównane. Ponadto do wymiany danych i komunikacji zostanie wykorzystana technologia Internetu przedmiotów (IoT). **Wieloczujnikowy system do monitorowania zanieczyszczeń wody w rzece**

**Keywords:** Multiple sensor, WSNs, River water, Pollution, Monitoring.

**Słowa kluczowe:** zanieczyszczenie wody, czujniki.

## Introduction

Water pollution is one of the issues that have been raised in some areas in Indonesia. This research focussed on Siak River located in the Riau Province because of the issue of river pollution identified since a few years ago but which until now has got no significant solution from the respective authorities. Riau Province is located in central Sumatera Island in Indonesia. This province has 5 long and deep rivers, one of which is the deepest in Indonesia. Many companies, including those processing pulp and paper, which are predominant, and small companies, operate along the Siak River. Unfortunately, sometimes these companies release pollutants which contaminate the river. These river contaminants are from various sources such as industrial wastes, chemical spills and community and residence wastes. Flooding and other disasters might also contribute to the pollution of the river. This research aims to introduce a pollution monitoring system, which is a basic sensing system that incorporates 4 parameters: temperature, dissolved oxygen (DO), water pH, and electrical conductivity.

The conventional techniques to measure the quality of water using several methods have been as discussed [1-4]. The methods collect river water and information regarding the water quality are obtained in the laboratory, including biological, chemical and physical parameters of the water. However, these methods are time-consuming and expensive to use for getting full information, as many samples need to be taken and analysed. Real-time water quality monitoring system using WSNs has become popular in recent years because of the advantages of technology to collect data and information through the sensor node. The requirements for continuous data monitoring for water quality in a real-time system to establish trend and predict behavior from the history are discussed in [5-9].

A biological sensing system for detection of water quality is a method to detect bacteria using a computer vision system in analysis, and chemical analysis of the pollutant, as discussed [10-12]. The use of multi-sensors for the water pollutant detection system for the basic parameters is not limited to a few parameters. The use of locals for the collection of the data to support the monitoring system that has limited access is elaborated [13-16]. Image processing contributes to the remote sensor in analyzing and monitoring water quality at a long distance. In the previous research, the maximum distance was 10 meters for the image analysis [17, 18]. In deep waters or rivers, the use of robotic system for water quality detection has several advantages. Another scenario is in the ocean where mobile communication can assist in the detection of water quality. In other research conducted uses the method for polluted water detection but ineffective way to collect the data, furthermore the case of polluted water detection in the small scale of area as discussed [19-22].

In this research, multiple sensors are proposed to study water quality or polluted water. Multiple sensors are able to achieve better analysis of the samples compared to the detection using a single sensor. The basic parameters proposed are temperature, water pH, electrical conductivity and DO. Output gained from this approach will contribute to valuable knowledge for the monitoring of water quality in rivers. The transfer of data between WSNs nodes to a node sink for smooth data communication is also a part of the objectives of this work. Siak River, being one of the longest and deepest rivers in Riau Province, Indonesia, was chosen for the studies.

## Multiple Sensor System of WSNs

The multiple sensors system was designed to incorporate four parameters for the establishment of river

water pollutant index, and the results for all the sensors provided information on how polluted the water was. A complete block diagram of WSNs system is shown in figure 1. The Arduino Uno was used as sensor signal conditioning as it has ability to serve analogue and digital input with internal Analog to Digital Converter (ADC), Raspberry Pi3 for Microcontroller Unit (MCU) as data processing and Radio Frequency (RF) transceiver was Texas Instrument module CC1310 for RF communication among the sensor nodes. In the last step of the system block diagram, an antenna was used to transmit the signal and information to the other sensor node and send the information to the data centre.

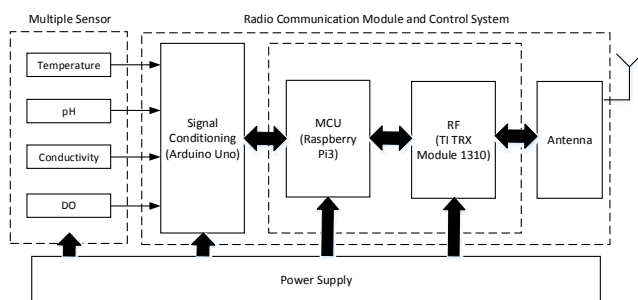

Fig. 1. Block diagram of multiple sensors system.

The complete expected indicators of measurement and range of the results in the unit as well as the accuracy are shown in Table 1.

Table 1. Design Specification of the multiple sensors system

Parameter	Range	Accuracy	Method
pH	0 to 14	± 0.1	Glass Electrode
Temperature	0 to 16 ° C	± 0.5 ° C	Thermistor
Dissolve Oxygen	0 to 20 mg/L	± 0.5 mg/L	Polarography
Electrical Conductivity	0 to 50	± 0.5	Conductivity Measurement

### System Design for Polluted Water Detection

In the proposed design of the multiple sensing systems for polluted water using four parameters as mentioned earlier, every sensor contributed to the collection of data and outcome of the analyses in the system. To detect common polluted water in real time, the sensing system must be deployed to the river. Solar system is required to supply power to the system because of its remote location with no electricity available. In this case, a set of solar panels with backup battery was provided, based on the capacity of the sensing system that had been tested. In the monitoring of polluted river water, there are several external factors that need consideration such as the environment, weather whether, temperature, etc. Based on the earlier testing, some parameters increased abnormally with an exponential curve. This is because some of the sensing surface was covered by foreign materials that registered high signal, but fortunately this took place for just a short time.

The design of multiple sensors uses several modes of sensing and one of it is temperature sensor, which contributed to thermistor with non-linear parameter between temperature and internal resistance. The range of temperature sensor was from 0°C to 40°C. The scale of temperature was selected based on early measurement and average temperature of Siak River water as well as environmental conditions in Pekanbaru City in Riau Province. In common use, the thermistor is valid for high temperature, which is more than 300°C, thus a low range of

temperature is better in detection to avoid the nonlinearity. The resistance of sensor can be scaled using general formula as invented in Steinhart-Hart thermistor third order approximation and can be written as in equation (1) [2]:

$$(1) \frac{1}{T} = A + B \cdot \ln(R) + C \cdot (\ln(R))^3$$

where T indicates the temperature of water detected in degree kelvin and R is the measured resistance in Ohm. The parameters A, B, and C are standard constants that were obtained from the manufacturer. These parameters determine the accuracy reading of the sensor. When the sensor was powered, voltage was induced across the thermistor at the fed point and went into the operational amplifier to gain and fine-tune the off-set signal. The value of voltage output from the sensor was in analogue, which must be converted to digital to match with the WSNs system which used Arduino microcontroller. The value of thermistor internal resistance is very much dependent on manufacturer. With regard to the resistance for room temperature (for example 25°C) with 20k ohm, the characteristics can be written as in equation (2):

$$(2) R_T = |R_0 \cdot e^{\beta \cdot \frac{1}{T} - \frac{1}{T_0}}$$

where RT is the resistance of the thermistor at T and the temperature is in Kelvin. The value of T0 is 298.15°K (or 25°C) and the value of beta is based on manufacturer's datasheet and specification. Equation 3 was used to calculate the temperature based on manufacturer's datasheet as a comparison to the actual value detected during testing. The results of temperature based on the analysis using equation (3) were required for the calibration of the temperature as detected by the sensor.

$$(3) T = \frac{\beta}{\ln \frac{R}{R_{\infty}}}$$

where:

$$(4) R_{\infty} = R_0 \cdot e^{-\beta/T_0}$$

The flow of process in the system is started with establishment of connection from WSNs node to sink in order to confirm all the nodes connected. Water sensors may be in sleep mode to save the power; then, to retrieve sensor data have to on the sensor before start the detection (wake up), followed by reading all the sensor data. All the data retrieve will send to sensor node sink as gate way to the monitoring system, in the node sink (gate way) has an internal memory to record all the data before sending to backend system (server), in the screen as monitoring system shows the all the data, once abnormal data detected then an alert send to respective department or authority.

The system design with real-time monitoring system was thus able to detect data from the sensors which must be transferred immediately with short delay. A block diagram for communication to the backend is shown in figure 2. Fourth Generation (4G) technology or General Package Radio Services (GPRS) was used and the river water pollution data were collected in an interval of time to minimize dumb and useless data that could be a waste in local memory. Universal Asynchronous Receiver/Transmitter (UART) unit was used as interface between MCU and the 4G communication unit.

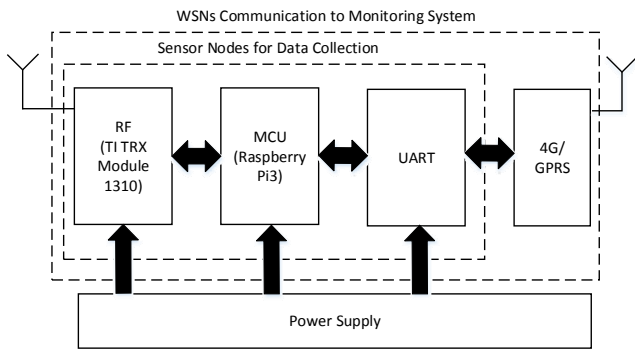

Fig. 2. Proposed diagram for WSNs sink node communication to sensors.

The multiple sensors system has been done on a prototype as well as tested in the laboratory. Sensors for the detection of river water pollutants as shown in the specifications in table 1 were fabricated to connect to the microcontroller. Figure 3 shows the fabricated system tested on a mini scale. Results show that the system was able to read all the water parameters which are shown in the LCD display. The next step was to test the prototype after improving the casing to be taken to the riverside.

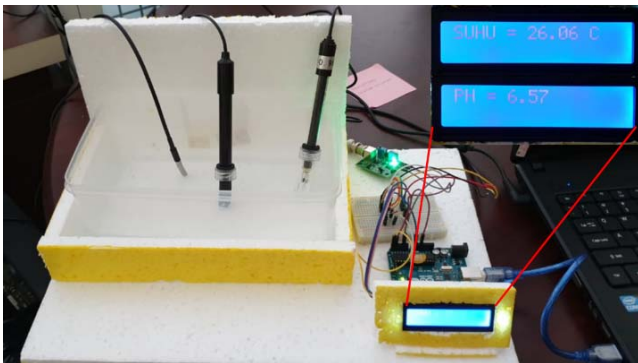

Fig. 3. Prototype of multiple sensors for detecting water pollutants.

The testing was done in the laboratory for a long period of time to check its long-term performance. Results show that the readings for the various parameters gave accurate results when compared to the manual calibration or the conventional way. The use of multiple systems for detection is good because it provides various indicators of polluted water to be analyzed to ensure that the final result for determining polluted water is more accurate. Furthermore, introducing an intelligent system on microcontroller program.

The design of multiple sensors system consists of four parameters which are common indicators of polluted water, but the sensor node for WSNs was able to serve up to five nodes or locations in 10 of sink nodes. The distance of sensing system node from a location to others according to site survey must not be more than 500 meters because longer distance results in low accuracy because of the fast river water flow, especially during rainy season. The system was supplied with independent power system from the solar panel because some locations were very far away from the electrical utility. Figure 4 shows an actual scan of Siak River located in the capital of Riau Province. A set of sensors under testing on-site was used to get the readings for analysis and calibration to be compared to the actual value. Many activities on the river created the pollution to the river and effected the sensor reading. Needless to say, the

polluted river water can be very hazardous to the community when consumed or used for daily activities.



Fig. 4. A set of sensors under testing on-site.

## Results and Discussion

The results from the in-house testing system that measures temperature, water pH, electrical conductivity and DO are compared to those from the conventional system which manually measures the quality of the tested water. Preliminary testing is very important to make sure that the readings of the sensing system are accurate compared to the actual conditions. Some of the results from the sensors were compared to other datasheets and literature in reference [2]. A good agreement of results from the two methods was found Figure 5. The deviation between the sensing system and the readings of a manual thermometer is very minimal (0.071°C to 1°C).

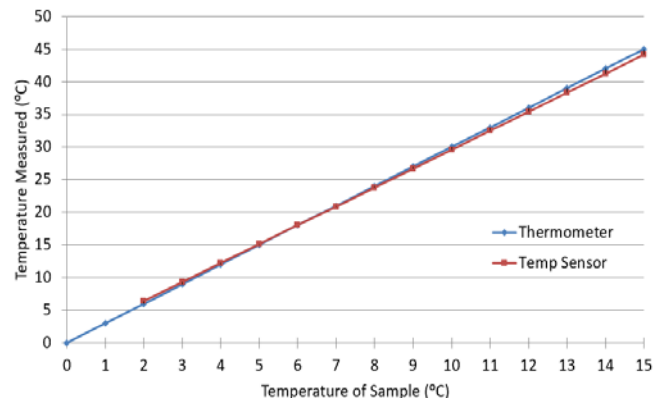

Fig. 5. Comparison of temperature obtained from the proposed system to that obtained using conventional method using thermometer.

Electrical conductivity is one of the indicators used to obtain information on a polluted water. –Small error in the results based on testing for the electrical conductivity is expected to enable high accuracy in the determination of water pollution. Normally, the error in this measurement is not more than 15%, similar to other indicators of polluted water. Good agreement of results was found in the comparison between readings of simulated electrical conductivity and the actual signal conditioning Figure 6.

Another common indicator to measure water quality is water pH. The sensing system for detection of water pH was designed to integrate other sensors and results were analyzed using the same microcontroller. Referring to the table 1, the specification of pH within the range from 0 to 14 is within 0.1 accuracy. Figure 7 shows the results of measured water pH compared to the theoretical.

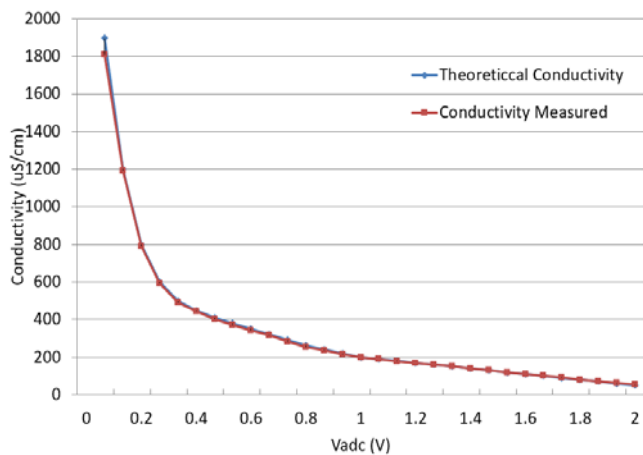

Fig. 6. Test results of the electrical conductivity of the sensor node

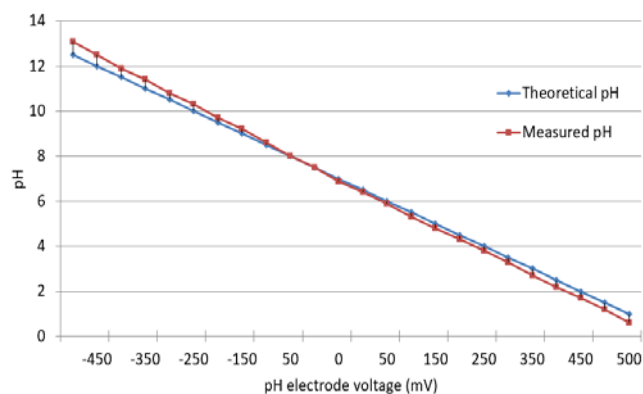

Fig. 7. Water pH test results versus theoretical values.

According to the initial testing in the laboratory, all the sensors were able to function well and were able to detect water parameters, as displayed on the LCD. Further action is required to install and to do testing at the actual site as the proposed system. The results were expected to achieve high accuracy based on actual content of polluted water. Figure 8 shows the results of water flow meter between manual and sensing systems.

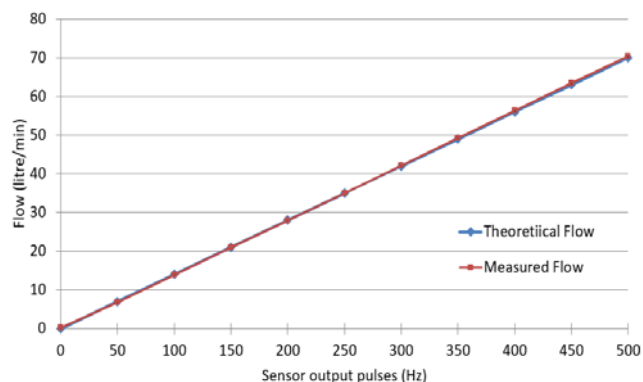

Fig. 8. Water flow meter test versus theoretical analysis.

According to the initial testing in the laboratory for all the parameters of the water, good agreement of results between the conventional measurement unit and the sensing systems was found. Thus, the proposed system will have a significant beneficial impact on the community and further step was taken to test on-site for real environmental conditions. The proposed system applied both WSNs and IoT technology for monitoring. Distance between sensing node and the sampling site is one of the considerations to

achieve good and representative readings of the sensing system.

## Conclusion

A system has been proposed for the assessment of water pollution using multiple sensors. The fabricated unit was tested in the laboratory as well as initial testing on-site. Results show good agreement between the proposed system and that of conventional measurement. Four main indicators in the sensing system, which were water pH, temperature, DO and electrical conductivity were measured to assess the quality of river water. The proposed system applies intelligent system as well in programming the microcontroller to achieve high accuracy in the final decision based on the detected values. Further actions to get a sensing system that is beneficial to the community and which includes water level and flow are required to include in the integrated sensing system for flood warning. Finally, to make sensing system smart, intelligent algorithm should be applied to microcontroller programming because of the various types of material and chemicals in the water.

*Appreciation to the Ministry of Research, Technology and Higher Education (KEMENRISTEKDIKTI) of Indonesia for funding this research project, to Universitas Islam Riau, Indonesia for providing the support facilities, as well as to Chiba University, Japan, and Universiti Teknologi PETRONAS, Malaysia.*

**Authors:** Dr. Evizal Abdul Kadir and Sri Listia Rosa, Department of Informatics Engineering, Faculty of Engineering, Universitas Islam Riau, Pekanbaru, Indonesia 28284, [evizal@eng.uir.ac.id](mailto:evizal@eng.uir.ac.id), [srilistiarosa@eng.uir.ac.id](mailto:srilistiarosa@eng.uir.ac.id); Assoc. Prof. Dr. Hitoshi Irie, Center for Environmental Remote Sensing (CEReS) Chiba University, Chiba, Japan, [hitoshi.irie@chiba-u.jp](mailto:hitoshi.irie@chiba-u.jp); Assoc. Prof. Dr. Mahmud Othman, Fundamental and Applied Sciences Department, Universiti Teknologi PETRONAS, Seri Iskandar, Perak, Malaysia 32610, [mahmud.othman@utp.edu.my](mailto:mahmud.othman@utp.edu.my).

## REFERENCES

- [1] Y. Guo *et al.*, "An Inversion-Based Fusion Method for Inland Water Remote Monitoring," *IEEE Journal of Selected Topics in Applied Earth Observations and Remote Sensing*, vol. 9, no. 12, pp. 5599-5611, 2016.
- [2] N. A. Cloete, R. Malekian, and L. Nair, "Design of Smart Sensors for Real-Time Water Quality Monitoring," *IEEE Access*, vol. 4, pp. 3975-3990, 2016.
- [3] Y. Wang, S. M. S. M. Rajib, C. Collins, and B. Grieve, "Low-Cost Turbidity Sensor for Low-Power Wireless Monitoring of Fresh-Water Courses," *IEEE Sensors Journal*, vol. 18, no. 11, pp. 4689-4696, 2018.
- [4] Marjolijn Woutersen *et al.*, "Development and Validation of an On-Line Water Toxicity Sensor with Immobilized Luminescent Bacteria for On-Line Surface Water Monitoring," *MDPI Sensor*, vol. 17, no. 2682, pp. 1-14, 2017.
- [5] L. Y. Li, H. Jaafar, and N. H. Ramli, "Preliminary Study of Water Quality Monitoring Based on WSN Technology," in *2018 International Conference on Computational Approach in Smart Systems Design and Applications (ICASSDA)*, 2018, pp. 1-7.
- [6] E. A. Kadir, S. L. Rosa, and A. Yulianti, "Application of WSNs for Detection Land and Forest Fire in Riau Province Indonesia," in *2018 International Conference on Electrical Engineering and Computer Science (ICECOS)*, 2018, pp. 25-28.
- [7] G. Lockridge, B. Dzwonkowski, R. Nelson, and S. Powers, "Development of a Low-Cost Arduino-Based Sonde for Coastal Applications," *MDPI Sensor*, vol. 16, no. 528, pp. 1-16, 2016.
- [8] T. Islam and Y. K. Lee, "A Two-Stage Localization Scheme with Partition Handling for Data Tagging in Underwater Acoustic Sensor Networks," *MDPI Sensor*, vol. 19, no. 2135, pp. 1-27, 2019.
- [9] E. A. Kadir, A. Siswanto, S. L. Rosa, A. Syukur, H. Irie, and M. Othman, "Smart Sensor Node of WSNs for River Water Pollution Monitoring System," in *2019 International Conference*

- on *Advanced Communication Technologies and Networking (CommNet)*, 2019, pp. 1-5.
- [10] F. Yuan, Y. Huang, X. Chen, and E. Cheng, "A Biological Sensor System Using Computer Vision for Water Quality Monitoring," *IEEE Access*, vol. 6, pp. 61535-61546, 2018.
- [11] W.-C. Lin, K. Brondum, C. W. Monroe, and M. A. Burns, "Multifunctional Water Sensors for pH, ORP, and Conductivity Using Only Microfabricated Platinum Electrodes," *MDPI Sensor*, vol. 17, no. 1655, pp. 1-9, 2017.
- [12] Y. Lu, D. Macias, Z. S. Dean, N. R. Kreger, and P. K. Wong\*, "A UAV-Mounted Whole Cell Biosensor System for Environmental Monitoring Applications," *IEEE Transactions on NanoBioscience*, vol. 14, no. 8, pp. 811-817, 2015.
- [13] T. P. Lambrou, C. C. Anastasiou, C. G. Panayiotou, and M. M. Polycarpou, "A Low-Cost Sensor Network for Real-Time Monitoring and Contamination Detection in Drinking Water Distribution Systems," *IEEE Sensors Journal*, vol. 14, no. 8, pp. 2765-2772, 2014.
- [14] J. Tian and Y. Wang, "A novel water pollution monitoring approach based on 3s technique," in *2010 International Conference on E-Health Networking Digital Ecosystems and Technologies (EDT)*, 2010, vol. 1, pp. 288-290.
- [15] M. Grossi, R. Lazzarini, M. Lanzoni, A. Pompei, D. Matteuzzi, and B. Riccò, "A Portable Sensor With Disposable Electrodes for Water Bacterial Quality Assessment," *IEEE Sensors Journal*, vol. 13, no. 5, pp. 1775-1782, 2013.
- [16] E. A. Kadir, A. Efendi, and S. L. Rosa, "Application of LoRa WAN Sensor and IoT for Environmental Monitoring in Riau Province Indonesia," in *5th International Conference on Electrical Engineering, Computer Science and Informatics (EECSI 2018)*, Malang, 2018: IEEE.
- [17] C. Doña, J. M. Sánchez, V. Caselles, J. A. Domínguez, and A. Camacho, "Empirical relationships for monitoring water quality of lakes and reservoirs through multispectral images," *IEEE Journal of Selected Topics in Applied Earth Observations and Remote Sensing*, vol. 7, no. 5, pp. 1632-1641, 2014.
- [18] S. Olatinwo and T.-H. Joubert, "Optimizing the Energy and Throughput of a Water-Quality Monitoring System," *Sensors*, vol. 18, no. 4, p. 1198, 2018.
- [19] P. Teixidó, J. Gómez-Galán, F. Gómez-Bravo, T. Sánchez-Rodríguez, J. Alcina, and J. Aponte, "Low-Power Low-Cost Wireless Flood Sensor for Smart Home Systems," *Sensors*, vol. 18, no. 11, p. 3817, 2018.
- [20] F. D. V. B. Luna, E. d. I. R. Aguilar, J. S. Naranjo, and J. G. Jagüey, "Robotic System for Automation of Water Quality Monitoring and Feeding in Aquaculture Shadehouse," *IEEE Transactions on Systems, Man, and Cybernetics: Systems*, vol. 47, no. 7, pp. 1575-1589, 2017.
- [21] Z. Wu, J. Liu, J. Yu, and H. Fang, "Development of a Novel Robotic Dolphin and Its Application to Water Quality Monitoring," *IEEE/ASME Transactions on Mechatronics*, vol. 22, no. 5, pp. 2130-2140, 2017.
- [22] E. O'Connor, A. F. Smeaton, N. E. O'Connor, and F. Regan, "A Neural Network Approach to Smarter Sensor Networks for Water Quality Monitoring," *MDPI Sensor*, vol. 12, pp. 4605-4632, 2012.