

## Steady State Stability Limit Assessment when Wind Turbine Penetrated to the Systems using REI Approach

**Abstract.** High-powered wind turbines in the electric power system lead to a significant challenge in balancing production power and electrical power consumption caused by the winds intermittent. In this study, assessing the steady state stability limit (SSSL) in South Sulawesi system when wind turbines is penetrated the Sidrap bus using the REI-Dimo method. The method developed by Paul Dimo was later known as the Radial Equivalent Independent (REI)-Dimo to determine the stability of the system, the condition of the generator which is still stable when a disturbance or load changes occur. REI-Dimo serves to determine the Z equivalent to the generator so that a state of stability can be known. This study is conducted to determine the stability of the steady state generator in South Sulawesi system with 15 generators, 44 buses on the 150kV interconnection system. The simulation results show that the normal condition is  $0.0323^\circ$ , the Critical clearing angle is  $111.903^\circ$ , and the condition of the 100% loading of the critical clearing angle is  $90.00^\circ$ .

**Streszczenie.** W artykule założono limit stanu trwałej stabilności SSSL w systemie w prowincji South Sulawesi. Wykorzystano metodę zaproponowaną przez Paula Dimo znaną jako Radial Equivalent Independent (REI)-Dimo do określania stabilności systemu kiedy warunki pracy generatora są stabilne przy zakłóconym odbiorze. Założenie stałego limitu stanu stabilności w warunkach połączenia turbin wiatrowych do systemu przy wykorzystaniu metody REI

**Keywords:** steady state stability limit, wind turbine, penetration, REI-Dimo, CCA.

**Słowa kluczowe:** limit stanu stabilności SSSL, metoda REI-Dimo, trurbiny wiatrowe

### Introduction

In the past decade, the increase in electricity loads has risen sharply, so that the extensive use of fossil fuel power plants produces a lot of gas so that air pollution, global warming, and climate change become problems in various countries. For this reason researchers are developing renewable energy sources (RES) to save and reduce the effects of global warming to reduce fossil fuels by 30% of the total energy generation. From various RES sources, various regions that have the potential of wind turbines have been developed. The South Sulawesi electricity system has installed wind turbines in the Sidrap area of 75MW which are connected to a 150kV transmission line. Wind turbines are the most environmentally friendly type of generator and the most promising resource as a source of energy, economically this plant is very profitable because it does not require production costs, but stability can potentially bring negative impact to the electricity system. The penetration of intermittent power output from wind turbines due to uncertainty in wind speed which has a negative impact on the stability of the electric power system in South Sulawesi [1,2]

Installing the wind turbine on a 150kV transmission line on the South Sulawesi system can have an increase in stability when the power supply does not fluctuate, but this can result in a decrease in system stability when the fluctuations in changes in weather conditions and wind speed. The penetration of wind turbine needs to be considered because it can reduce the critical clearing angle (CCA) when the interference, rotor angle stability, distance, frequency, control between the generator occurs and the control mode of the system is briefly interrupted [3-5]

In general it has been divided into two categories the WTG have been they are, fixed speed and variable speed. The fixed speed of WTG generally uses a squirrel cage generator (SCIG) to convert mechanical energy from a wind turbine to electrical energy. Then the multiple-generator input induction and direct synchronous generator (DDSG) are popular types of variable speed WTG [6,7]

Steady State Stability is a system state of operating conditions where the system is still in a condition after a change in load or interference [8,9]

In the ref [10] It is defined that the system stability in the load change condition can change the position of the rotor. To solve the stability problem, there are several methods that have been proposed to improve system performance

In the ref [11] using virtual inertia and frequency control parameters to maintain frequency stability on a grid with high penetrated renewable energy. besides contributing to the frequency of virtual inertia also participating in reactive power control.

In the ref [12] to improve transient stability in transmissions by using SVC auxiliary equipment with TID (Tilt Integral derivatives) controllers based on fuzzy Logic controllers. To increase stability by using this method is faster by injecting reactive power to the load because SVC is in a transmission adjacent to the load. Using this simulation there is less processing time and can suppress oscillations in the system.

There have been many methods to determine steady state stability, in the ref [13] algorithm to determine the stability of the system under Penetrated high renewable energy, the results show that wind power plants are greater than 2,300-2,400MW of stability criteria are met for N configurations, but can cause instability or high risk of instability for N-1 configurations. In the ref [14,15] validating the evaluation of steady state stability using Dimo Approximation.

In ref [16,17] regulates the scheduling of power plants to increase the stability limit on interconnecting 500kV systems. The results of this method are the highest level of steady state stability compared to the maximum optimization method is when the peak load at night.

Therefore, in this paper it is intended to conduct a study of the stability steady-state limit in south Sulawesi system that has installed 75MW wind turbines in the area by implementing the REI-Dimo Methodology. This paper is organized as follows. In the first part, explain the background, in part 2, the study of system power model, then study of the methodology applied to section 3. For part 4 describes the analysis and purpose. The last part describes the conclusion.

### Power system model

The South Sulawesi power system model discussed in this paper is shown in Figure 1 which consists of a 44-bus main system and 15 generators.

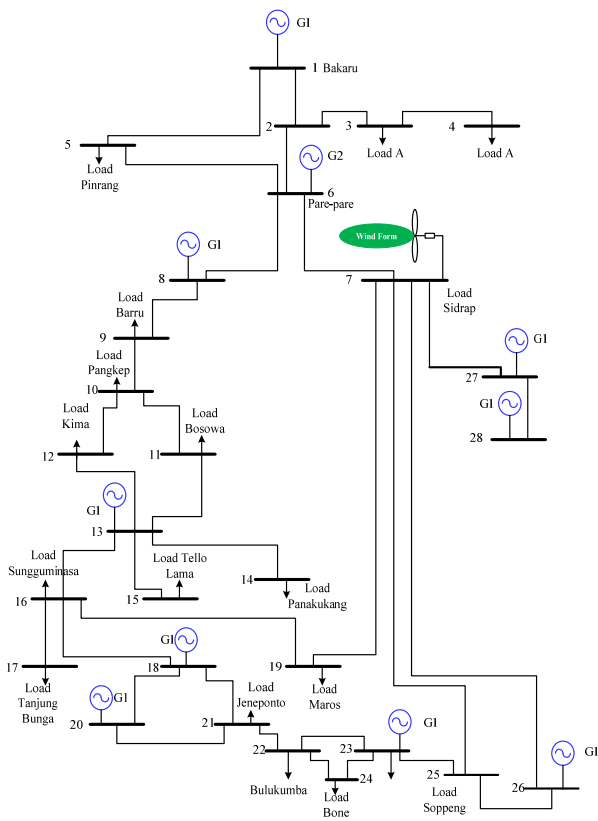

Fig. 1. South Sulawesi system

### Determination and Stability of Stable Conditions

Several methods have been developed in analyzing electric power systems, to determine the conditions of transient and steady state stability. The first method is the same criteria as Equal Area Criterion or (EAC). This method directly determines the critical time in the Critical Clearing Time (CCT) machine, to determine the condition of a multi-machine or large-scale system, this system cannot be used. The second method is, the flow of power (CPF) is widely used to determine the loading parameters connected to the bus voltage. The CPF method is used to formulate load flow power in load parameters. To determine it can be expressed through the following equation:

$$(1) \quad (\theta, V) = AK$$

where:

$\lambda$  = load parameter,  $\theta$  = bus voltage angle vector,  $V$  = bus voltage vector;  $K$  = vector which describes the change in the percentage of load on each bus

Third, load flow is used to determine the total load on each bus, but when a load flow is added, the load flow method does not converge so that system conditions cannot be ascertained. This method uses the Newton Raphson method which is an upgrade to Gauss-Seidel. The basis used in the calculation is matrix admittance ( $Y_{bus}$ )

Of the three methods, in this study applied a steady state stability analysis on the South Sulawesi system using the Independent Equivalent Radial method. This method was introduced by Paul Dimo so it is known as the REI-DIMO method. This method can shorten storage time to reduce the system.

### Equal Area Criterion

System stability can be improved using the same broad criteria method. This method is based on a graphical interpretation of energy use and reserves. This method can

be applied to a system of two engines or a single machine connected to a bus without limits. The swing equation on the machine is represented as follows:

$$(2) \quad M\ddot{\delta} + P_{em} = P_{sh}$$

with

$$(3) \quad P_{em} = P_{max} \sin \delta$$

Equation (3) is a form of equation of the state of oscillation. For one swing on the generator. In this condition the system is considered stable. So the first maximum equation is as follows:  $\delta$  reach maximum and can be reduced:

$$(4) \quad \frac{d\delta}{dt} = 0$$

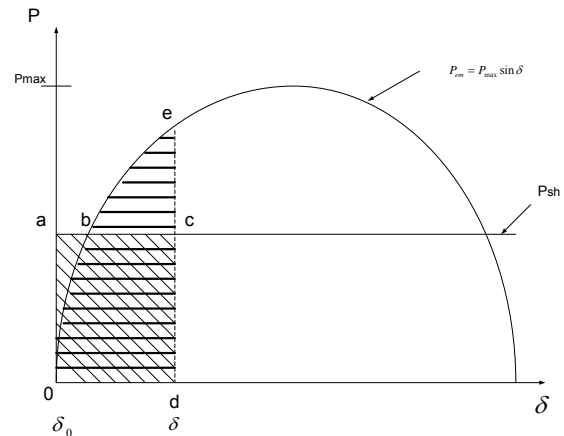

Fig. 2. The same width criteria when changing the load

Figure 2 is a picture of machine operation that matches the mechanical input strength  $P_{m0} = P_{e0}$ . The increase in input power is represented by a horizontal line  $P_{m1}$ . If  $P_{m1} > P_{e0}$  there will be an increase in the rotor angle.

If  $P_{m1} > P_{e0}$  there will be an increase in the rotor angle  $\delta$ .

$$(5) \quad \int_{\delta_0}^{\delta} P_{sh} d\delta = \text{Extent of a-b-c-d-0}$$

$$(6) \quad \int_{\delta_0}^{\delta} P_{em} d\delta = \text{Size of 0-b-e-c-d}$$

Energy provided by rotor rotation

$$(7) \quad \int_{\delta_0}^{\delta} P_{em} d\delta = \text{Size of 0-b-e-c-d}$$

The result of the rotor swing at point b and the angle is area  $a-b-0 = \text{area } b-c-e$ .

### Wind turbine model

The model equation for mechanical power output from wind turbines obtained from wind power can be calculated as follows:

$$(8) \quad P_w = 0.5 \rho \pi R^2 V_w^3 C_p(\lambda, \beta)$$

Wind power output ( $P_w$ ), rotor blade radius ( $R$ ), wind speed ( $V_w$ ),

$$(9) \quad C_p(\lambda, \beta) = c_1 \left( \frac{c_2}{\lambda_i} - c_3 \beta - c_4 \right) e^{-\frac{c_5}{\lambda_i}} + c_6 \lambda$$

with

$$(10) \quad \lambda = \frac{\omega_r R}{V_w}$$

Wind power output (Pwt) Rotor blade radius (R) Wind speed (Vw) The power coefficient depends on the tip ratio) $\lambda$ ) calculates based on air density ( $\rho$ ) power coefficient ( $C_p$ ) blade pitch angle ( $\beta$  as stated in (8), (9) and (10) here  $c_1$  to  $c_6$  is the coefficient of wind turbine characteristics and  $r$  is the wind turbine rotational speed.

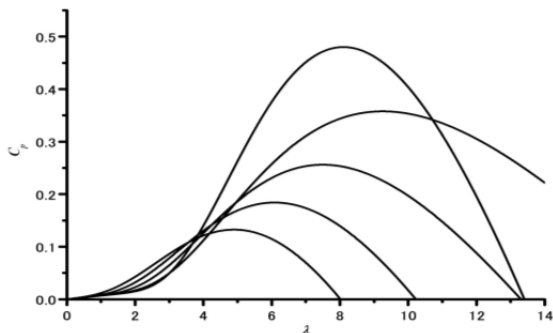

Fig. 3. Characteristics of Wind Turbine

### Rei-Dimo

The prominent concept of the very unique REI-Dimo method of the same type of linearizing injection replaces the transmission network with constant admission, the complex transmission network with constant reception, then connected to the fictitious load bus load. The network is called a zero power balance network which is the main concept of REI-Dimo.

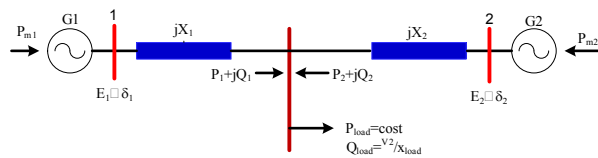

Fig. 4. Thevenin Circuit

In Figure 5, addressing the numerical step of the process builds a zero power LAN network. REI-Dimo, introduces zero power balance to classify a single load system to a load center, which is a fictitious load along with maintaining the nature and balance of the basic power of the system.

In the radial system from REI, one of the rules applies steady state stability reactive power (voltage stability). In a system of 1 ... .. i ..., G Generator, synchronous condenser

and active injectors on DC ties or AC ties, connected radially to the system, on one of the buses the load is fictitious or through admittance  $Y_1, \dots, Y_i, \dots, Y_G$ . So the equation can be built as follows:

$$(11) \quad \frac{d\Delta Q}{dV} = \sum_m \frac{Y_m E_m}{\cos \delta_m} - 2(\sum_m Y_m + Y_{load})V$$

$E_m$  = Internal tension of the engine;  $\delta_m$  = internal angle of the machine with reference to  $V$  voltage on the load bus (fictitious and actual)

For the real part represented by the MW value, for the reactive load to vary with the square of the voltage in the following equation:

$$(12) \quad Y_{Load} = \frac{Q_{load}}{V^2}$$

remains, for the criteria equation developed from equation (12) as follows:  $\phi$  The  $Q_{load}$  value is recalculated at each step by considering the constant load structure,  $\cos$

$$\frac{d\Delta Q}{dV} = \sum_m \frac{Y_m E_m}{\cos(\delta_m \gamma_m)} - 2 \left( \sum_m Y_m \cos \gamma_m + Y_{load} + Y^\gamma \right) V$$

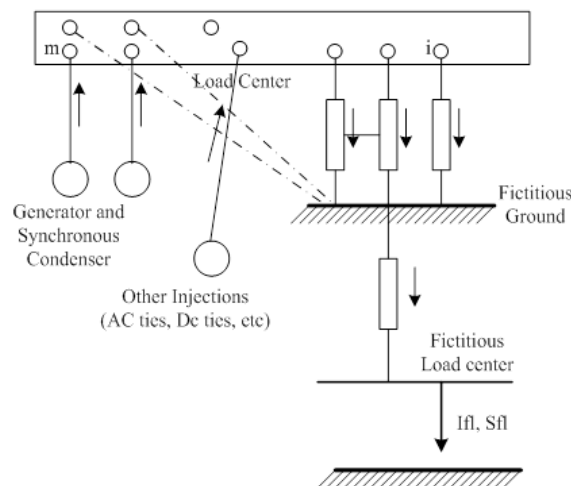

Fig. 5. Zero power balance network

Table 1. Operating System actual conditions

No.Bus	Voltage	Angle -	Load		Generator	
	Mag.	Degree	MW	Mvar	MW	Mvar
1	1.03	0	3.5	0.2	47.225	79.568
2	0.997	-1.366	17.1	4.1	0	0
3	0.988	-2.718	23.3	3.7	0	0
4	0.981	-3.274	9.6	4.8	0	0
5	1	-0.132	24.4	6.2	14.3	-49.721
6	0.996	-0.87	18.7	4.7	0	0
7	1	0.443	0	0	31.1	-2.244
8	0.974	4.734	26.5	10.3	0	0
9	1	-3.614	0	0	60.4	63.501
10	0.953	-12.058	10.1	2.4	0	0
11	0.944	-14.57	22.1	8	0	0
12	0.947	-15.928	0	0	0	0
13	0.918	-17.736	18.9	10.6	0	0
14	0.941	-15.264	33.1	15.4	0	0
15	0.953	-17.866	18	5.8	0	0
16	1	-16.016	63.3	18.3	21	90.758
17	0.98	-18.572	68.3	17.7	0	0
18	0.981	-20.521	0	-20	0	0
19	1	-21.317	11.4	0	5.2	13.564

20	0.951	-19.782	24.3	2.6	0	0
21	0.957	-22.003	45.5	2.8	0	0
22	1	-16.025	0	0	0	0
23	1.001	-16.034	0	0	0	0
24	1	-16.88	19.7	4.7	12.6	18.115
25	0.975	-19.285	0	0	0	0
26	0.958	-19.48	26.5	7.7	0	0
27	1	-9.356	15.7	3.6	20	129.111
28	0.968	-12.192	55.2	16.7	0	0
29	1	20.743	20.6	4.7	79	28.459
30	0.959	0.729	18.6	5.5	0	0
31	1	30.519	0	0	196.1	-0.573
32	0.983	19.439	17.4	3.4	0	0
33	0.989	12.671	27.1	6.5	0	0
34	1	11.106	21.9	4.6	4	69.558
35	0.99	10.533	32.1	8.2	0	0
36	0.975	10.142	14.1	3.4	0	0
37	1	14.142	28.4	11.5	265.2	-34.481
38	1	6.236	11.9	1.5	8.2	69.807
39	1	39.2	49.2	0	4	128.97
40	0.972	62.54	0	0	0	0
41	1	106.778	0	0	195	55.638
42	0.993	105.315	0	0	0	0
43	0.989	104.738	4.9	0.5	0	0
44	0.986	103.885	11	1.8	0	0
Total			812.4	181.9	963.325	660.031

### Discussion and analysis

In Table 1, the implementation of the Rei-Dimo method in the South Sulawesi system produces load flow. In Table 2, it shows that steady state stability as described by the criteria is as wide as using Equation 4. Running simulation to see the stability index when a load changes.

Table 2. Steady Index State stability when changes in load

% Addition	rotor angle	Index Stability	Critical clearing angle
Normal	0.0323	-9.7841	111.903
10%	0.0323	-9.7841	107.131
20 %	0.0292	-9.3778	99.134
40%	0.0260	-8.9665	88.173
60%	0.0226	-8.5422	78.916
80%	0.0191	-8.0933	71.863
100%	0.0153	-7.6035	68.660
100 more	0.0153	-7.6035	90.000

Each load change occurs at an angle of normal condition 0.0323, for the stability index -9.7841 which is in the form of a curve as illustrated in Figure 6. For the addition of load 10 angle values and stability index is the same as normal, but for the Critical clearing angle decreases represented in Figure 7.

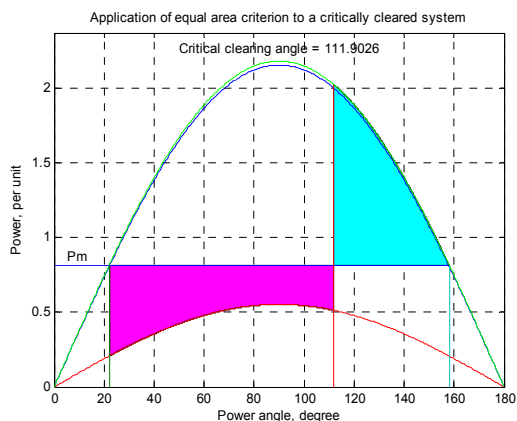

Fig. 6. the criteria curve is the same under normal load conditions.

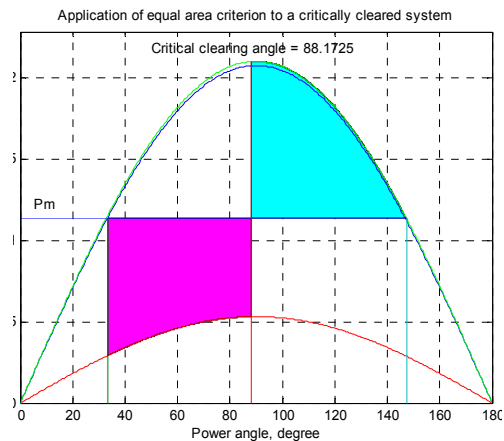

Fig. 7. the criteria curve is the same at the condition that the load increases by 40%

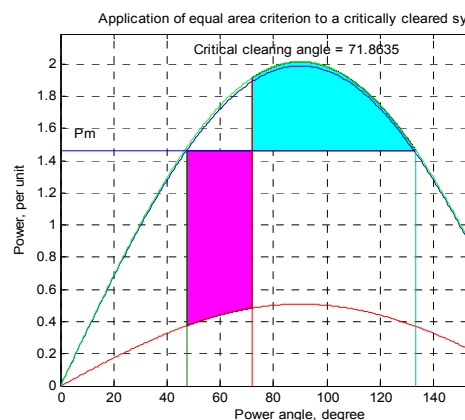

Fig. 8. the criteria curve is broad at the condition that the load increases by 80%

The angle of 0.0323 when experiencing an additional load of 20% makes 0.0292, with the stability index -9.3778, for the Critical clearing angle represented with an angle value of 99.134°. for the addition of 40% the load value of the angle is 0.0260, the stability index is -8.9665 which has

a decrease of  $-0.4113$ . for Critical clearing angle worth  $88,173$  in load 40 is represented in Figure 7. The addition of 40% of load makes the Critical clearing angle decrease by 50% more so this is very dangerous to the system condition. then for the addition of 60%, the value of the Critical clearing angle  $78.916$  is represented, has a stability index of  $-8.5422$  with an angle of  $0.0226$ . in this condition the operation of the electric power system must be vigilant, because if it is still experiencing additional oscillation loads it can increase sharply. In Figure 8 is the same broad criterion for the addition of 80% load with a Critical clearing angle of  $71,863$ , so that the Stability Index is  $-8.0933$  and the angle becomes narrower with a value of  $0.0191$ . in this simulation for the addition of 100% load with an angle value of  $0.0153$  and the stability index  $-7.6035$  with a Critical clearing angle worth  $68,660$  represented in Figure 9. For the steady state stability the generator angle should be less than  $90^\circ$  if more than that then the system is loose and angular becomes 0 as in Figure 10.

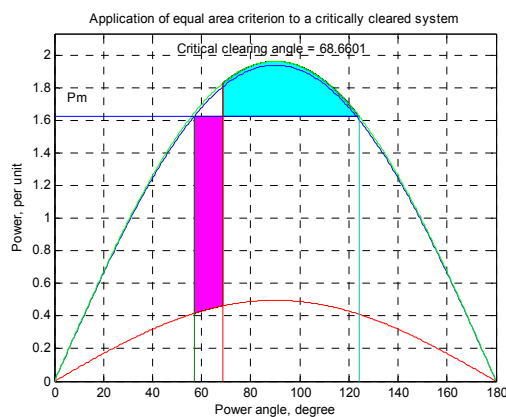

Fig. 9. the criteria curve is the same in the condition of the load increasing by 100%

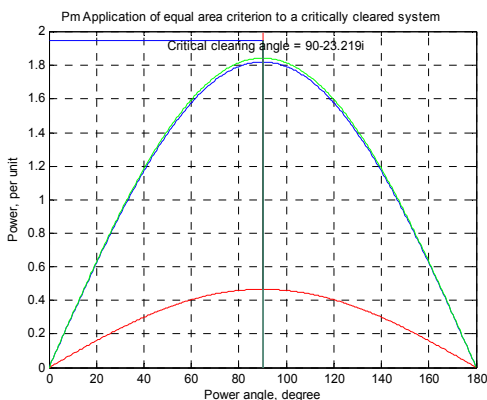

Fig. 10. the criteria curve is equal in area under the condition of increasing 100% more

## Conclusions

Using REI-DIMO to analyze the stability of the steady state electric power system of South Sulawesi by reducing the transmission transmission which is 44 buses to 16 buses. Analysis of generator stability limits can be seen using the same broad criteria curve for each generator. The generator angle is out of sync when passing the maximum limit of  $90^\circ$ . The load condition is very influential on the Critical clearing angle so that each change in load is followed by changes in the rotor angle and the Stability Index. The results of the South Sulawesi system simulation can be seen that the normal condition is  $0.0323^\circ$ , Critical

clearing angle  $111,903$  steady state generator, safe condition even though it has increased load. Whereas when given a load of 100% the angle changes to  $0.0153^\circ$ , the stability index  $-7.6035$  and Critical clearing angle  $68.660^\circ$ , so when there is an additional 100% load, the Critical clearing angle value becomes  $90.00^\circ$ . the system will come out black out.

**Authors.** Agus SISWANTO<sup>1,2</sup>, Ansar SUYUTI<sup>2</sup>, Indar CHAERAH GUNADIN<sup>2</sup>, Sri MAWAR SAID<sup>2</sup>  
 Department of Electrical Engineering, Faculty of Engineering University of Hasanuddin Makassar Indonesia (1), University of 17 Agustus 1945 Cirebon, Indonesia (2)  
 Agus Siswanto <asiswanto.untagcrb@gmail.com>

## REFERENCES

- [1] Setiadi, H., et al., *Modal interaction of power systems with high penetration of renewable energy and BES systems*. International Journal of Electrical Power & Energy Systems, 2018. 97: p. 385-395.
- [2] Siswanto, A., et al., *Stability improvement of wind turbine penetrated using power system stabilizer (PSS) on South Sulawesi transmission system*. AIP Conference Proceedings, 2018. 1941(1): p. 020036.
- [3] Shah, R., N. Mithulanathan, and R.C. Bansal, *Oscillatory stability analysis with high penetrations of large-scale photovoltaic generation*. Energy Conversion and Management, 2013. 65: p. 420-429.
- [4] Mehta, B., P. Bhatt, and V. Pandya. *Small signal stability analysis of power systems with DDSG based wind power penetration*. in *2014 IEEE PES Asia-Pacific Power and Energy Engineering Conference (APPEEC)*. 2014.
- [5] Yuli Asmi, R., A. Siswanto, and I. Mahmudi, *Stability issues in presence variable distributed generation into radial distribution network*. Vol. 218. 2018. 01005.
- [6] Gautam, D., V. Vittal, and T. Harbour. *Impact of increased penetration of DFIG based wind turbine generators on transient and small signal stability of power systems*. in *IEEE PES General Meeting*. 2010.
- [7] Piatek, K., A. Firlit, and D. Wojciechowski, *Field experience with Statcom in application to wind farms*. 2015. 1-5.
- [8] Savulescu, S.C., et al., *Fast steady-state stability assessment for real-time and operations planning*. IEEE Transactions on Power Systems, 1993. 8(4): p. 1557-1569.
- [9] Darusman, B.M., S. Ansar, and G. Indar Chaerah, *Small Signal Stability Analysis of Wind Turbine Penetration in Sulselrabar Interconnection System*. Journal of Physics: Conference Series, 2018. 1090(1): p. 012034.
- [10] C.W. Taylor, *Power system Voltage Stability*. New York, Mc.Graw Hill,, 1994.
- [11] Hajiakbari Fini, M. and M.E. Hamedani Golshan, *Determining optimal virtual inertia and frequency control parameters to preserve the frequency stability in islanded microgrids with high penetration of renewables*. Electric Power Systems Research, 2018. 154: p. 13-22.
- [12] Sharma, T. and A. Dahiya. *Transient stability improvement in transmission line using SVC with Fuzzy Logic based TID controller*. in *2014 IEEE 6th India International Conference on Power Electronics (IICPE)*. 2014.
- [13] Chimirel, C.L., M. Eremia, and S. Enache. *Algorithm for steady-state stability assessment under high penetration of probabilistic renewable energy generation conditions*. in *2016 18th Mediterranean Electrotechnical Conference (MELECON)*. 2016.
- [14] Gunadin, I., S. Said, and M. Irsan, *Determination of stability index of electrical power system using REI-Dimo methods*. Vol. 90. 2016. 161-167.
- [15] Goh, H.H., et al. *Validation of steady-state stability evaluation exerting with Dimo's approximation*. in *4th IET Clean Energy and Technology Conference (CEAT 2016)*. 2016.
- [16] Gunadin, I.C., A. Soeprijanto, and O. Penangsang, *Real Power Generation Scheduling to Improve Steady State Stability Limit in the Java-Bali 500 kV Interconnection Power System*. World Acad. Sci. Eng. Technol, 2010. 72: p. 1-5.
- [17] Ansar Suyuti, I.K.a.Y.S.A., *The Impact Of The Operation Planning Of Power Plants For Environmental Emissions In South Sulawesi*, ARPN Journal of Engineering and Applied Sciences, 2017 VOL. 12.,